

Q2 . 糸切り関係 / Thread trimmer mechanism

< -02 >

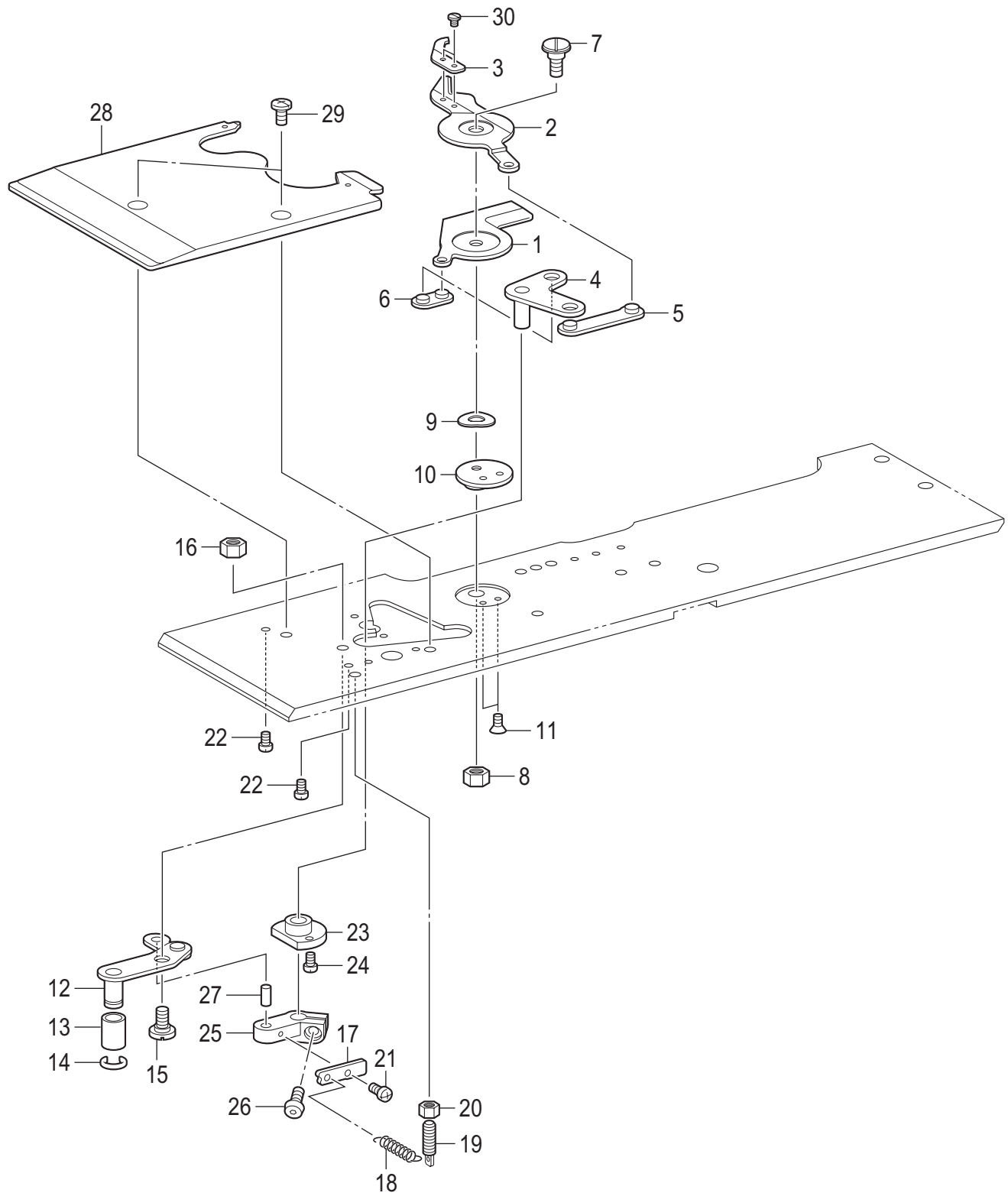

Q2. 糸切り関係 / Thread trimmer mechanism

REF.NO	CODE	Q'TY	品名	NAME OF PARTS	RM
			<-02用>	<For -02>	
1	SA6988001	1	イドウハR	MOVABLE KNIFE R	
2	SA6989001	1	イドウハL	MOVABLE KNIFE L	
3	SA6990001	1	イトサバキ	THREAD HANDLER	
4	SA6991001	1	イドウハクドウイタ	MOVABLE KNIFE DRIVING PLATE	
5	SA6992001	1	イトキリリンクAクミ	THREAD TRIMMER LINK A ASSY	
6	SA6994001	1	イトキリリンクBクミ	THREAD TRIMMER LINK B ASSY	
7	S37660101	1	ダンネジM4	SHOULDER SCREW, M4	
8	021400202	1	2シュナット4	NUT 2 M4	
9	S37654000	1	ナミザガネ	WAVE WASHER	
10	S37655101	1	メスササエザガネ	KNIFE SUPPORT WASHER	
11	141542001	2	サラネジ3.18	SCREW 3.18	
12	SA6996001	1	イトキリリンクレバーJクミ	THREAD TRIMMER L-LEVER J ASSY	
13	SA7778001	1	リンクレバーコロ	LINK LEVER ROLLER	
14	137191051	1	クリセントトメワ	STOP RING	
15	SA5693001	1	ダンネジM4	SHOULDER SCREW M4	
16	021400306	1	3シュナット4	NUT 3 M4	
17	SA6998001	1	バネカケ	SPRING HOOK	
18	SA6999001	1	イトキリバネ	THREAD TRIMMER SPRING	
19	S34902001	1	バネカケ	SPRING HOOK	
20	021350106	1	1シュナット35	NUT 1 M3.5	
21	062260406	1	ナベコ26X4	SCREW PAN M2.6X4	
22	062300416	2	ナベコ3X4	SCREW PAN M3X4	
23	SA7001001	1	イトキリウデメタル	BUSH TR TRIMMER ARM	
24	062260516	2	ナベコ26X5	SCREW PAN M2.6X5	
25	SA7002001	1	イトキリレバーウデB	THREAD TRIMMER LEVER ARM B	
26	S21716001	1	ボタンヘッドネジ4X10	SCREW, BUTTON HEAD M4X10	
27	S37858000	1	ニードルピン4X8	NEEDLE PIN, 4X8	
28	SA7003001	1	オサエプレートJU	WORK CLAMP PLATE JU	
29	060400516	2	バインド4X5	SCREW BIND M4X5	
30	153787001	2	シメネジ2.38	SCREW, SM2.38	