

C1. 送り関係 / Feed mechanism

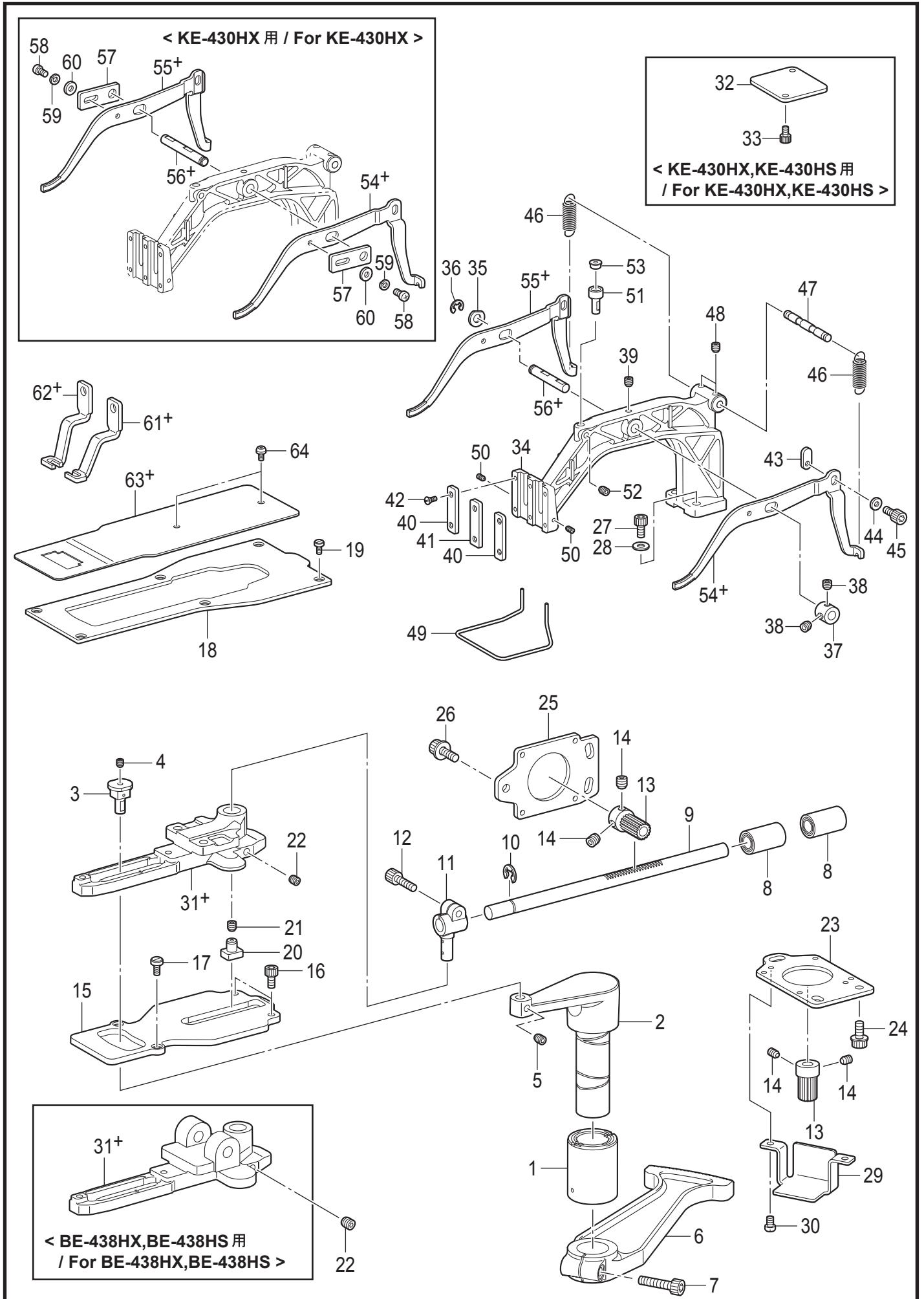

C1. 送り関係 / Feed mechanism

REF.NO	CODE	Q'TY	品名	NAME OF PARTS	RM
			<KE-430HX用>	<For KE-430HX>	
54+	SB6819001	1	QCオサエウデレバーR	WORK CLAMP ARM LEVER R	
55+	SB6820001	1	QCオサエウデレバーL	WORK CLAMP ARM LEVER L	
56+	SB4692001	1	QCオサエウデレバーク	WORK CLAMP ARM LEVER SHAFT	
57	SA3423101	2	QCレバークササエ	WORK CLAMP LEVER SUPPORT	
58	062500816	2	ナベコ5X8	SCREW PAN M5X8	
59	028050246	2	バネザガネ2-5	WASHER SPRING 2-5	
60	026050136	2	ヒラザガネコガタ5	WASHER PLAIN S 5	
			<KE-430HS用>	<For KE-430HS>	
54+	SB6821001	1	オサエウデレバーR	WORK CLAMP ARM LEVER R	
55+	SB6822001	1	オサエウデレバーL	WORK CLAMP ARM LEVER L	
56+	SB0929101	1	QCオサエウデレバーク	WORK CLAMP ARM LEVER SHAFT	
61+	P.52-54	1	オサエアシR	WORK CLAMP R	
62+	P.52-54	1	オサエアシL	WORK CLAMP L	
63+	P.52-55	1	オクリイタ	FEED PLATE	
64	153057101	2	オクリイタシメネジ	SCREW, ROUND W/SOCKET SM4.37	