

B. 针杆和挑线杆装置 / Needle bar and thread take-up mechanism

S7250A-

参照号	零部件序号	数量	零部件名称	NAME OF PARTS	RM
			<用于-□03>	<For -□03>	
1+	SB3770001	1	针杆连杆总组件	NEEDLE BAR CONNECTING ROD UNIT	
2+	SB3771001	1	针杆连杆组件	NEEDLE BAR CONNECTING ROD ASSY	
3+	SB3783001	1	针杆轴套 D	NEEDLE BAR BUSH D	
4+	*P.47-50	1	针杆 DB	NEEDLE BAR DB	
4+	*P.47-50	1	针杆 DP	NEEDLE BAR DP	
			<用于-□05>	<For -□05>	
1+	SB3777001	1	针杆连杆总组件	NEEDLE BAR CONNECTING ROD UNIT	
2+	SB3778001	1	针杆连杆组件	NEEDLE BAR CONNECTING ROD ASSY	
3+	SB3784001	1	针杆轴套 D	NEEDLE BAR BUSH D	
4+	*P.47-50	1	针杆	NEEDLE BAR	
5	SB7277001	1	上轴组件	UPPER SHAFT ASSY	
6	SB7278001	1	上轴	UPPER SHAFT	
7	SB2407001	1	橡皮塞 6.4	RUBBER CAP 6.4	
8	SB3447001	1	挑线杆曲柄组件	THREAD TAKE-UP CRANK ASSY	
9	014770632	3	螺钉 SM6.35-40X6	SET SCREW SOCKET SM6.35-40X6	
10	SB3769001	1	螺钉 SM7.14-28	SCREW SM7.14-28	
11	014771032	1	固定螺钉 SM6.35-40X10	SET SCREW SOCKET SM6.35-40X10	
12	SB7279001	1	绕线驱动轮	BOBBIN WINDER DRIVING WHEEL	
13	S23651001	2	固定螺钉 M6X6	SET SCREW SOCKET (FT) M6X6	
14	SA8145001	1	垫圈	WASHER	
15	140004001	1	螺钉 SM3.57-40X7	SCREW, SM3.57-40X7	
16	SA2422001	1	螺钉 SM3.57-40X6L	SCREW, SM3.57L	
17	158727001	1	油线 4X4 L=27	WICK, 4X4 L=27	
18	SB3775001	1	挑线杆支撑轴	THREAD TAKE-UP SUPPORT SHAFT	
19	SB3776001	1	紧圈	SET SCREW COLLAR	
20	012400536	2	螺钉 M4X5	SET SCREW SOCKET (FT) M4X5	
21	SA2161001	1	垫圈	WASHER	
22	048060342	1	挡圈 E6	RETAINING RING E6	
23	SA8436001	1	油毡	FELT	
24	012060636	2	螺钉 M6X6	SET SCREW SOCKET (FT) M6X6	
25	SB7280001	1	上轴轴套 M	UPPER SHAFT BUSH M	
26	SB3782001	1	针杆轴套 U	NEEDLE BAR BUSH U	
27	140553102	1	固定螺钉 SM3.18	SET SCREW, SM3.18	
28	SB3458001	1	针杆导向滑块	NEEDLE BAR GUIDE SLIDE BLOCK	
29	151594001	1	针杆过线环	NEEDL BAR THREAD GUIDE	
			<用于-□03>	<For -□03>	
30+	*P.47-50	1	针板 E18	NEEDLE PLATE E18	
			<用于-□03 日本>	<For -□03 Japan>	
30+	*P.47-50	1	针板 B18M	NEEDLE PLATE B18M	
			<用于-□05>	<For -□05>	
30+	*P.47-50	1	针板 H26	NEEDLE PLATE H26	
			<用于-□05 日本>	<For -□05 Japan>	
30+	*P.47-50	1	针板 B26	NEEDLE PLATE B26	
31	SB4190001	2	螺钉 SM4.37-40X8	SCREW FLAT SM4.37-40X8	
32	180018151	1	推板组件	SLIDE PLATE ASSY	
33	114561001	1	推板簧	SPRING, PLATE	
34	SA9523001	2	螺钉 SM2.38	SCREW SM2.38	
35	SB7282001	1	接头组件	JOINT ASSY	
36	S23651001	4	固定螺钉 M6X6	SET SCREW SOCKET (FT) M6X6	
			<用于-□03>	<For -□03>	
37+	*P.47-50	1	机针DBX1...(#11)	NEEDLE DBX1...(#11)	
37+	*P.47-50	1	机针DBX1...(#14)	NEEDLE DBX1...(#14)	
37+	*P.47-50	1	机针DPX5...(#11)	NEEDLE DPX5...(#11)	
			<用于-□05>	<For -□05>	
37+	*P.47-50	1	机针DBX1...(#22)	NEEDLE DBX1...(#22)	
37+	*P.47-50	1	机针DPX5...(#22)	NEEDLE DPX5...(#22)	

S-7250A-101

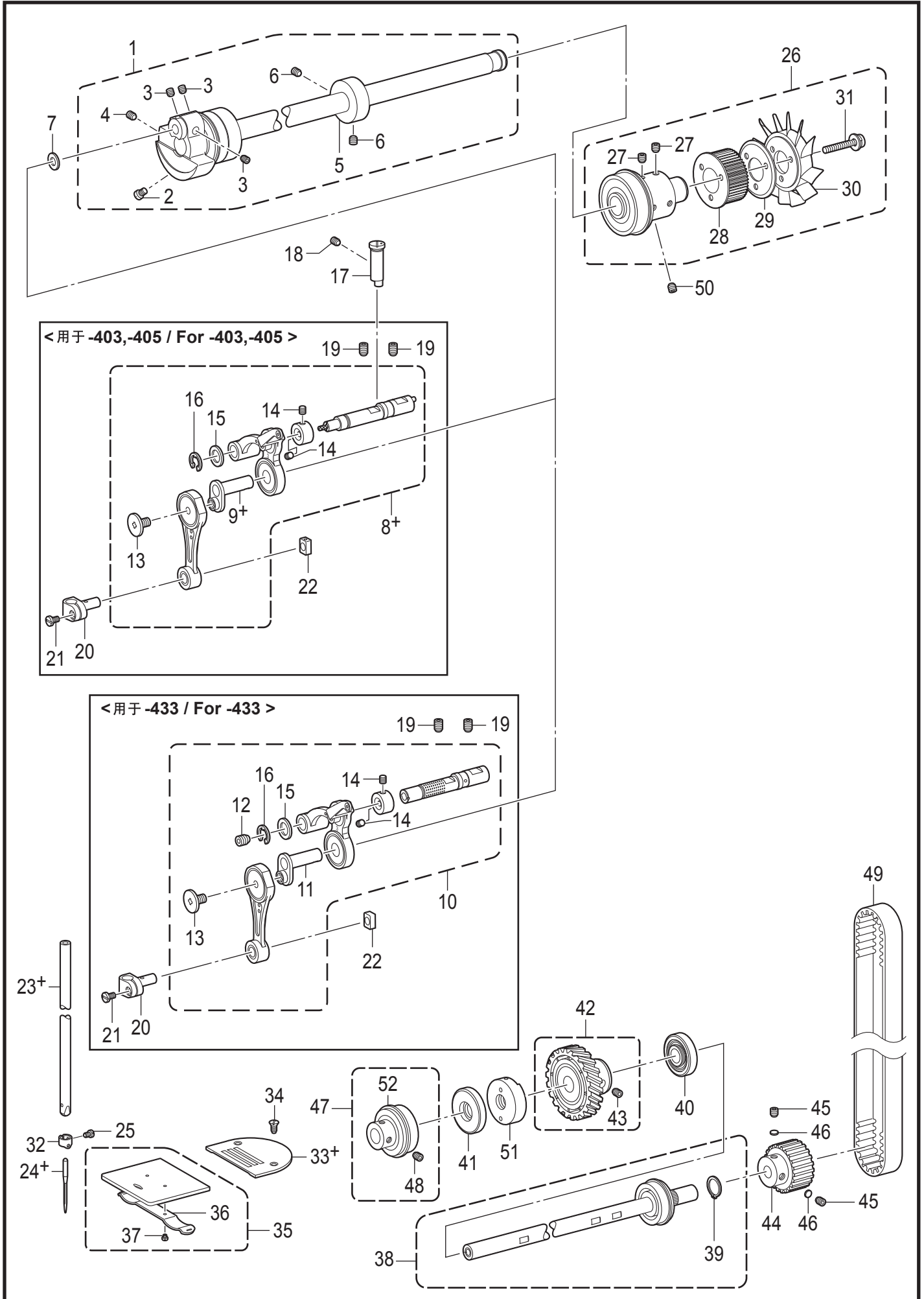

B1. 针杆和挑线杆装置 / Needle bar and thread take-up mechanism

参照号	零部件序号	数量	零部件名称	NAME OF PARTS	RM
1	SB9830001	1	上轴组件	UPPER SHAFT ASSY	
2	S25235001	1	螺钉 M8	SCREW M8	
3	S23651001	3	固定螺钉 M6X6	SET SCREW SOCKET (FT) M6X6	
4	S25236001	1	螺钉 M6X10	SET SCREW SOCKET (FT) M6X10	
5	SA1120001	1	绕线驱动轮	BOBBIN WINDER DRIVING WHEEL	
6	S23651001	2	固定螺钉 M6X6	SET SCREW SOCKET (FT) M6X6	
7	110367001	1	垫圈 8	WASHER, PLAIN SPECIAL 8	
			<用于-403>	<For -403>	
8+	SB2914001	1	针杆连杆总组件	NEEDLE BAR CONNECTING ROD SET	
9+	SA7628001	1	针杆曲柄	NEEDLE BAR CRANK	
			<用于-405>	<For -405>	
8+	SB2916001	1	针杆连杆总组件	NEEDLE BAR CONNECTING ROD SET	
9+	SA7626001	1	针杆曲柄	NEEDLE BAR CRANK	
			<用于-433>	<For -433>	
10	SB2915101	1	针杆连杆总组件	NEEDLE BAR CONNECTING ROD SET	
11	SA7628001	1	针杆曲柄	NEEDLE BAR CRANK	
12	SA8061001	1	螺钉封 M3X4	SET SCREW SOCKET(CP)M3X4 SEAL	
13	SA2422001	1	螺钉 SM3.57-40X6L	SCREW, SM3.57L	
14	012400436	2	螺钉 M4X4	SET SCREW SOCKET (FT) M4X4	
15	SA2161001	1	垫圈	WASHER	
16	048060342	1	挡圈 E6	RETAINING RING E6	
17	SA7239101	1	定位销	STOPPER PIN	
18	012500536	1	螺钉 M5X5	SET SCREW SOCKET (FT) M5X5	
19	012061036	2	螺钉 M6X10	SET SCREW SOCKET (FT) M6X10	
20	SA9650101	1	针杆接头	NEEDLE BAR CLAMP	
21	140004001	1	螺钉 SM3.57-40X7	SCREW, SM3.57-40X7	
22	SB1029101	1	角滑块D	SLIDE BLOCK D	
23+	* P.57	1	针杆	NEEDLE BAR	
			<用于欧洲以外: -4□3>	<Except for Europe: -4□3>	
24+	* P.57		机针DBX1...(#14)	NEEDLE DBX1...(#14)	
			<用于欧洲以外: -405>	<Except for Europe: -405>	
24+	* P.57		机针DBX1...(#22)	NEEDLE DBX1...(#22)	
			<用于欧洲: -4□3>	<For Europe only: -4□3>	
24+	* P.57		机针DBX5...(#14)	NEEDLE, DPX5...(#14)	
			<用于欧洲: -405>	<For Europe only: -405>	
24+	* P.57		机针DBX5...(#22)	NEEDLE, DPX5...(#22)	
25	140553102	1	固定螺钉 SM3.18	SET SCREW, SM3.18	
26	SB1537001	1	接头组件	JOINT UNIT	
27	S23651001	2	固定螺钉 M6X6	SET SCREW SOCKET (FT) M6X6	
28	SA2250101	1	同步轮U	TIMING PULLEY U	
29	S38712001	1	法兰	FLANGE	
30	S38713100	1	叶轮	FAN	
31	SA2404001	3	螺钉组件 M4X35DB	SCREW, PAN (S WASHER) M4X35	
32	151594001	1	针杆过线环	NEEDLE BAR THREAD GUIDE	
33+	* P.57-60	1	针板	NEEDLE PLATE	
34	151267001	2	螺钉 SM4.37-40X8	SCREW, FLAT SM4.37-40X8	
35	180018251	1	推板组件	SLIDE PLATE ASSY	
36	114561001	1	推板簧	SPRING, PLATE	
37	SA9523001	2	螺钉 SM2.38	SCREW SM2.38	
38	SA5278001	1	下轴组件	LOWER SHAFT ASSY	
39	048120142	1	轴用挡圈 C12	RETAINING RING EXTERNAL C12	
40	S25401100	1	油封	OIL SEAL	
41	SA1317101	1	油封	OIL SEAL	
42	SB2403001	1	下轴齿轮组件	LOWER SHAFT GEAR ASSY	
43	S23651001	2	固定螺钉 M6X6	SET SCREW SOCKET (FT) M6X6	
44	SA2251001	1	同步轮D	TIMING PULLEY D	
45	S23651001	2	固定螺钉 M6X6	SET SCREW SOCKET (FT) M6X6	
46	SA2378001	2	垫片 4.8	SPACER,4.8	