

S-7250A / S-7300A

V. 附件 / Accessories

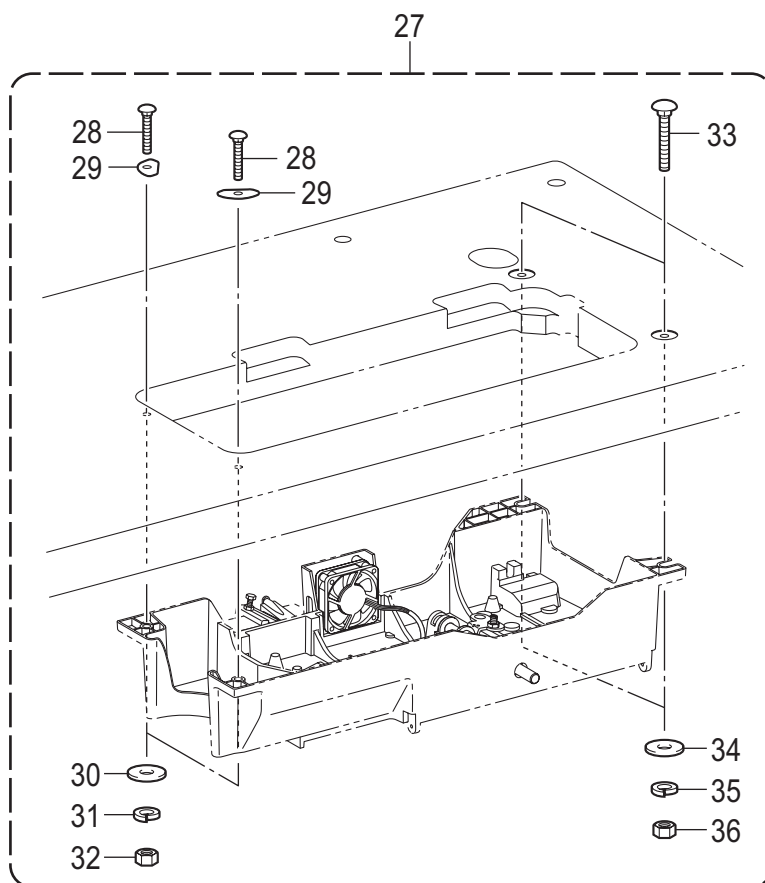

< 选购件 / Option parts >

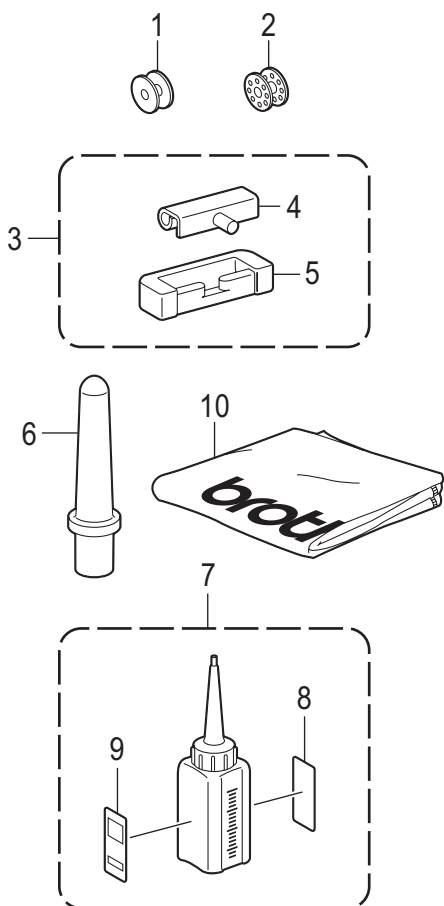
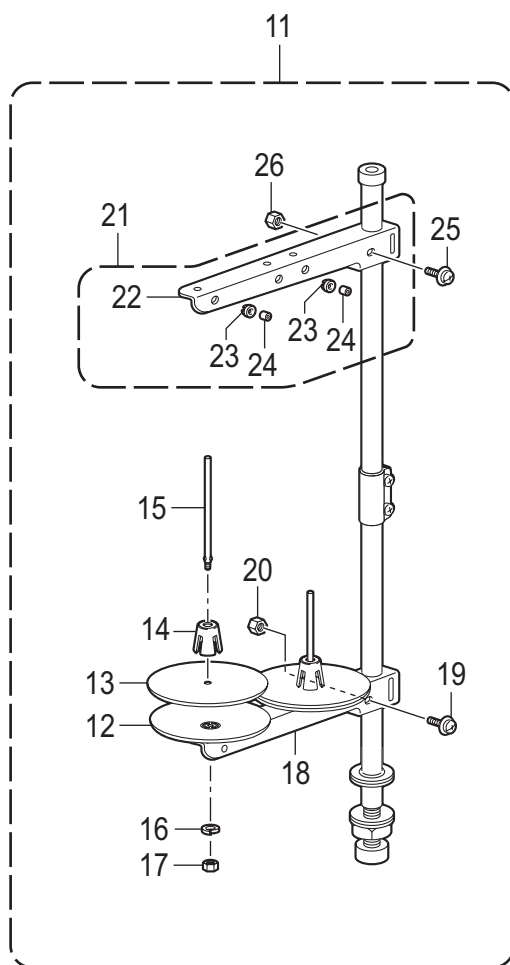
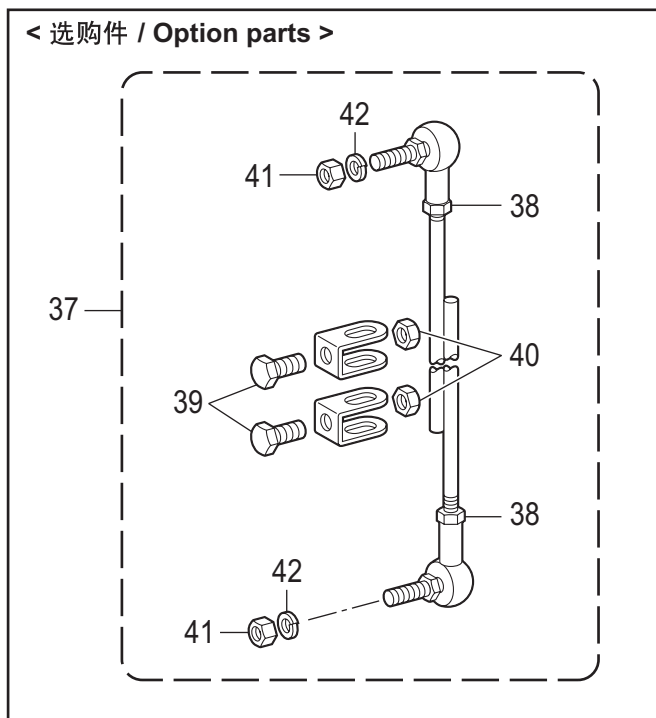

S-7250A / S-7300A

V. 附件 / Accessories

参照号	零部件序号	数量	零部件名称	NAME OF PARTS	RM
1	146290021	1	<用于-□03> 梭芯	<For -□03> BOBBIN	
2	117132001	1	<用于-□05> 梭芯	<For -□05> BOBBIN	
3	SB5633001	1	橡胶铰链组件	RUBBER HINGE ASSY	
4	SB3627001	2	机头铰链	HEAD HINGE	
5	SB3628001	2	机头铰链套	RUBBER CUSHION	
6	SB7377001	1	机头撑杆 S	HEAD REST S	
7	SA8239301	1	油壶组件	OIL TANK ASSY	
8	SB1270001	1	油壶警示标贴 英文	OIL WARNING LABEL EN	
9	SB1271101	1	油壶警示标贴 日文	OIL WARNING LABEL JP	
10	SB3876001	1	机头罩	HEAD COVER	
11	SB3928101	1	线架组件 2DR	COTTON STAND ASSY 2DR	
12	S51283001	2	垫圈	SPOOL STAND BASE	
13	SB4114001	2	线盘软垫	SPOOL MAT	
14	S51282101	2	线轴缓冲架	SPOOL CUSHION	
15	150179002	2	线轴 B	SPOOL SHAFT B	
16	SB4117001	2	弹簧垫圈 2-5	WASHER SPRING 2-5	
17	SB4119001	2	螺母 M5	NUT 2 M5	
18	S02778022	1	插线架 2	SPOOL HOLDER 2	
19	S37037002	1	螺钉(带垫圈) M5X32	SCREW PAN (S/P WASHER) M5X32	
20	SB4118001	1	螺母 M5	NUT 1 M5	
21	S02786002	1	上过线架2组件	THREAD HANGER ASSY, 2	
22	S02787002	1	过线架 2	THREAD HANGER 2	
23	150183000	2	过线管套	THREAD HANGER BASE	
24	142990001	2	过线架上过线管	THREAD BUSH	
25	SB4120001	1	螺钉(带垫圈) M5X14	SCREW PAN(S/P WASHER) M5X14	
26	SB4118001	1	螺母 M5	NUT 1 M5	
27	SB5634001	1	螺栓组件	BOLT SQUARE ASSY	
28	SB5047001	2	螺栓 M6X45	BOLT SQUARE M6X45	
29	SB5048001	2	安装板	SETTING PLATE	
30	025060332	2	平垫圈 L6	WASHER PLAIN L 6	
31	028060242	2	弹簧垫圈 2-6	WASHER SPRING 2-6	
32	021060106	2	螺母 M6	NUT 1 M6	
33	SA9893001	2	螺栓 M8X65	BOLT M8X65	
34	SB4243001	2	平垫圈 L8	WASHER PLAIN L 8	
35	028080242	2	弹簧垫圈 2-8	WASHER SPRING 2-8	
36	021080202	2	螺母 M8	NUT 2 M8	
37	S40765001	1	<选购件> 连杆组件	<Option parts> CONNECTING ROD ASSY	
38	021060103	2	螺母 M6	NUT 1 M6	
39	017081603	2	螺栓 M8X16	BOLT 8X16	
40	021080103	2	螺母 M8	NUT 1 M8	
41	S36119021	2	螺母 M6	NUT 1 M6	
42	S36121021	2	弹簧垫圈 2-6	WASHER SPRING 2-6	

S-7780A

V. 付属品関係 / Accessories

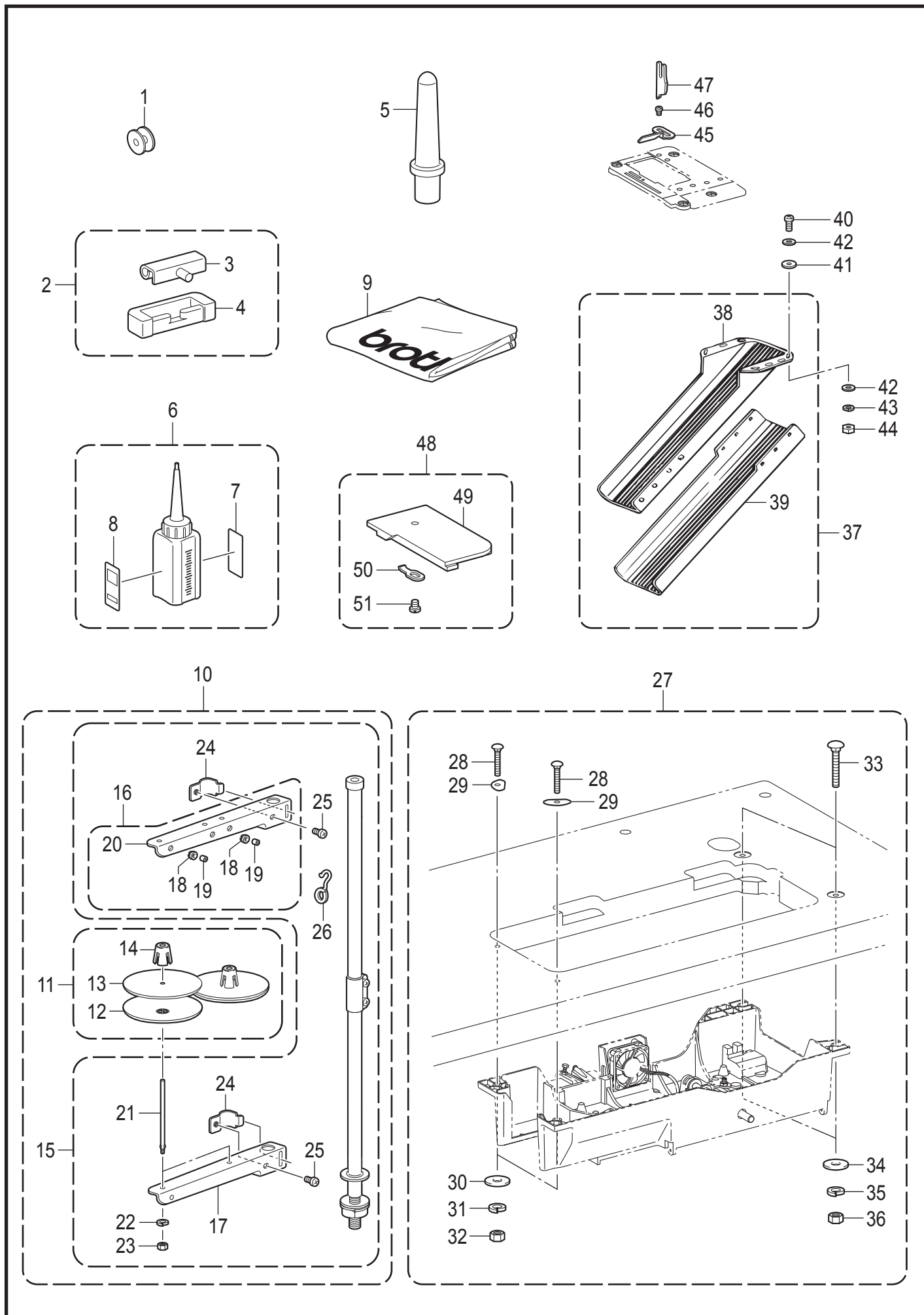

S-7780A-910

S-7780A

V. 付属品関係 / Accessories

REF.NO	CODE	Q'TY	品名	NAME OF PARTS	RM
1	146290001	1	ボビン	BOBBIN	
2	SB5633001	1	ラバーヒンジクミ	RUBBER HINGE ASSY	
3	SB3627001	2	トウブヒンジ	HEAD HINGE	
4	SB3628001	2	トウブヒンジウケゴム	RUBBER CUSHION	
5	SB7377001	1	マクラS	HEAD REST S	
6	SA8239301	1	オイルタンククミ	OIL TANK ASSY	
7	SB1270001	1	オイルケイコクラベル エイブン	OIL WARNING LABEL EN	
8	SB1271101	1	オイルケイコクラベル ワブン	OIL WARNING LABEL JP	
9	SB3876001	1	トウブカバー	HEAD COVER	
10	SB3928201	1	イトタテダイクミ2DR	COTTON STAND ASSY 2DR	
11	SB9789001	1	ウケザラクミ	SPOOL STAND BASE ASSY	
12	S51283001	2	ウケザラ	SPOOL STAND BASE	
13	SB4114001	2	スプ-ルマット	SPOOL MAT	
14	S51282101	2	スプ-ルクッション	SPOOL CUSHION	
15	SB9790101	1	イトタテダイコクミ	COTTON STAND SUB ASSY	
16	SA6608001	1	スレツドハンガ-クミ2	THREAD HANGER ASSY 2	
17	SA6607001	1	スプ-ルホルダ-2	SPOOL HOLDER 2	
18	150183000	2	イトカケハンガ-ダイ	THREAD HANGER BASE	
19	142990001	2	スレツドブツシユ	THREAD BUSH	
20	SA6607001	1	スプ-ルホルダ-2	SPOOL HOLDER 2	
21	150179002	2	スプ-ルジクB	SPOOL SHAFT B	
22	SB4117001	2	バネザガネ2-5	WASHER SPRING 2-5	
23	SB4119001	2	2シュナツト5	NUT 2 M5	
24	SA6609001	2	スプ-ルホルダ-ササエ	SPOOL HOLDER SUPPORTER	
25	062061616	2	ナベコ6X16	SCREW PAN M6X16	
26	S02747101	1	イトカケバネ	SPRING	
27	SB5634001	1	カクネクミ	BOLT SQUARE ASSY	
28	SB5047001	2	カクネボルト6X45	BOLT SQUARE M6X45	
29	SB5048001	2	シキイタ	SETTING PLATE	
30	025060332	2	ヒラザガネダイ6	WASHER PLAIN L 6	
31	028060242	2	バネザガネ2-6	WASHER SPRING 2-6	
32	021060106	2	1シュナツト6	NUT 1 M6	
33	SA9893001	2	カクネボルト8X65	BOLT M8X65	
34	SB4243001	2	ヒラザガネダイ8	WASHER PLAIN L 8	
35	028080242	2	バネザガネ2-8	WASHER SPRING 2-8	
36	021080202	2	2シュナツト8	NUT 2 M8	
37	SC0356001	1	ダスター-シユ-トクミ	DUSTER CHUTE ASSY	
38	SC0355001	1	ダスター-シユ-トL	DUSTER CHUTE L	
39	148432002	1	ダスター-シユ-トS	DUSTER CHUTE S	
40	062681412	4	ナベコ437-40X14	SCREW PAN SM4.37-40X14	
41	113691001	4	パツキン	PACKING	
42	SB2256001	8	ヒラザガネチュウ4.37	WASHER PLAIN 4.37	
43	028680242	4	バネザガネ2-4.37	WASHER SPRING 2-4.37	
44	105234003	4	ナツト4.37	NUT SM4.37	
45	S10631001	1	キリクズアンナイU	SEWING SCRAPS GUIDE, U	
46	062670412	2	ナベコ357-40X4	SCREW PAN SM3.57-40X4	
47	S10605301	1	ウワメス	UPPER KNIFE	
48	S10628101	1	ハリイタフタクミ	NEEDLE PLATE COVER ASSY	
49	S10629101	1	ハリイタフタ	NEEDLE PLATE COVER	
50	S10630001	1	スナツプイタバネ	SNAP PLATE SPRING	
51	141544001	1	シメネジ3.18	SCREW, SM3.18-40X3	

T-8421D / T-8422D / T-8452D / T-8722D / T-8752D

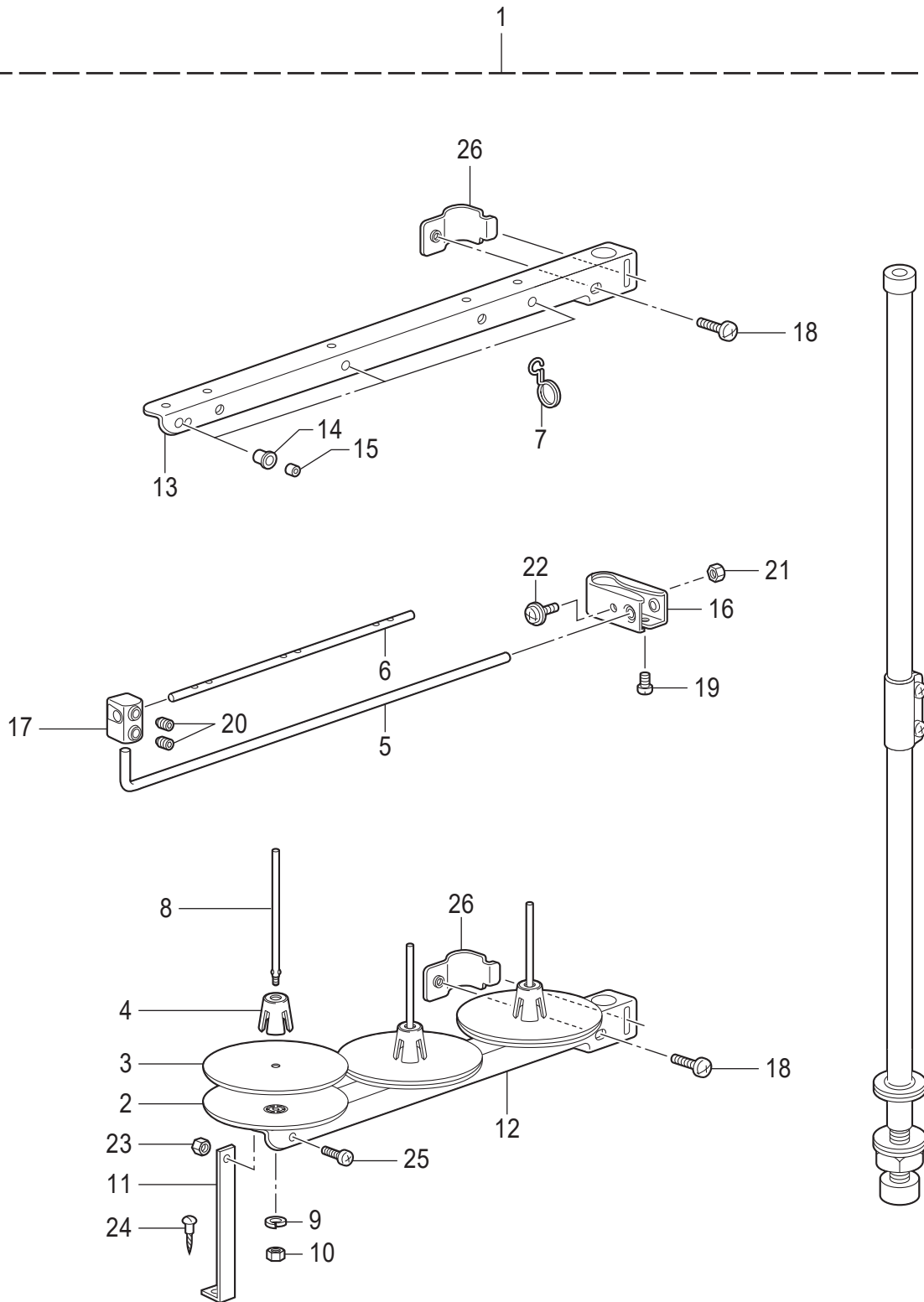

REF.NO	CODE	Q'TY	品名	NAME OF PARTS	RM
1	S07558509	1	イトタテダイクミ3DRTHF	COTTON STAND ASSY 3DRTHF	
2	S51283001	3	ウケザラ	SPOOL STAND BASE	
3	SB4114001	3	スプールマット	SPOOL MAT	
4	S51282101	3	スプールクッション	SPOOL CUSHION	
5	S04109001	1	イトアンナイササエボウ	THREAD GUIDE SUPPORT BAR	
6	142997001	1	イトアンナイ3	THREAD GUIDE, 3	
7	S02747101	1	イトカケバネ	SPRING	
8	150179002	3	スプールジクB	SPOOL SHAFT B	
9	SB4117001	3	バネザガネ2-5	WASHER SPRING 2-5	
10	SB4119001	3	2シュナツト5	NUT 2 M5	
11	150188009	1	スプールホルダー-ササエA	SPOOL HOLDER SUPPORT A	
12	SA6610001	1	スプールホルダー-3	SPOOL HOLDER 3	
13	SA6610001	1	スプールホルダー-3	SPOOL HOLDER 3	
14	150183000	3	イトカケハンガー-ダイ	THREAD HANGER BASE	
15	142990001	3	スレツドブツシユ	THREAD BUSH	
16	SA6615001	1	イトアンナイホルダー-	THREAD GUIDE HOLDER	
17	138843201	1	ササエボウツギテ	JOINT	
18	062061603	2	ナベコ6X16	SCREW PAN M6X16	
19	062061003	1	ナベコ6X10	SCREW PAN M6X10	
20	014060632	2	アナクボミ6X6	SET SCREW SOCKET (CP) M6X6	
21	SB4119001	1	2シュナツト5	NUT, 2 M5	
22	S37037001	1	ナベコヒラザ5X32	SCREW PAN (S/P WASHER) M5X32	
23	SB4119001	1	2シュナツト5	NUT, 2 M5	
24	032461606	1	+2マルモク45X16	WOOD SCREW ROUND 2 M4.5X16	
25	062501003	1	ナベコ5X10	SCREW PAN M5X10	
26	SA6609001	2	スプールホルダー-ササエ	SPOOL HOLDER SUPPORTER	

BAS 360H / 365H

BAS 370H / 375H

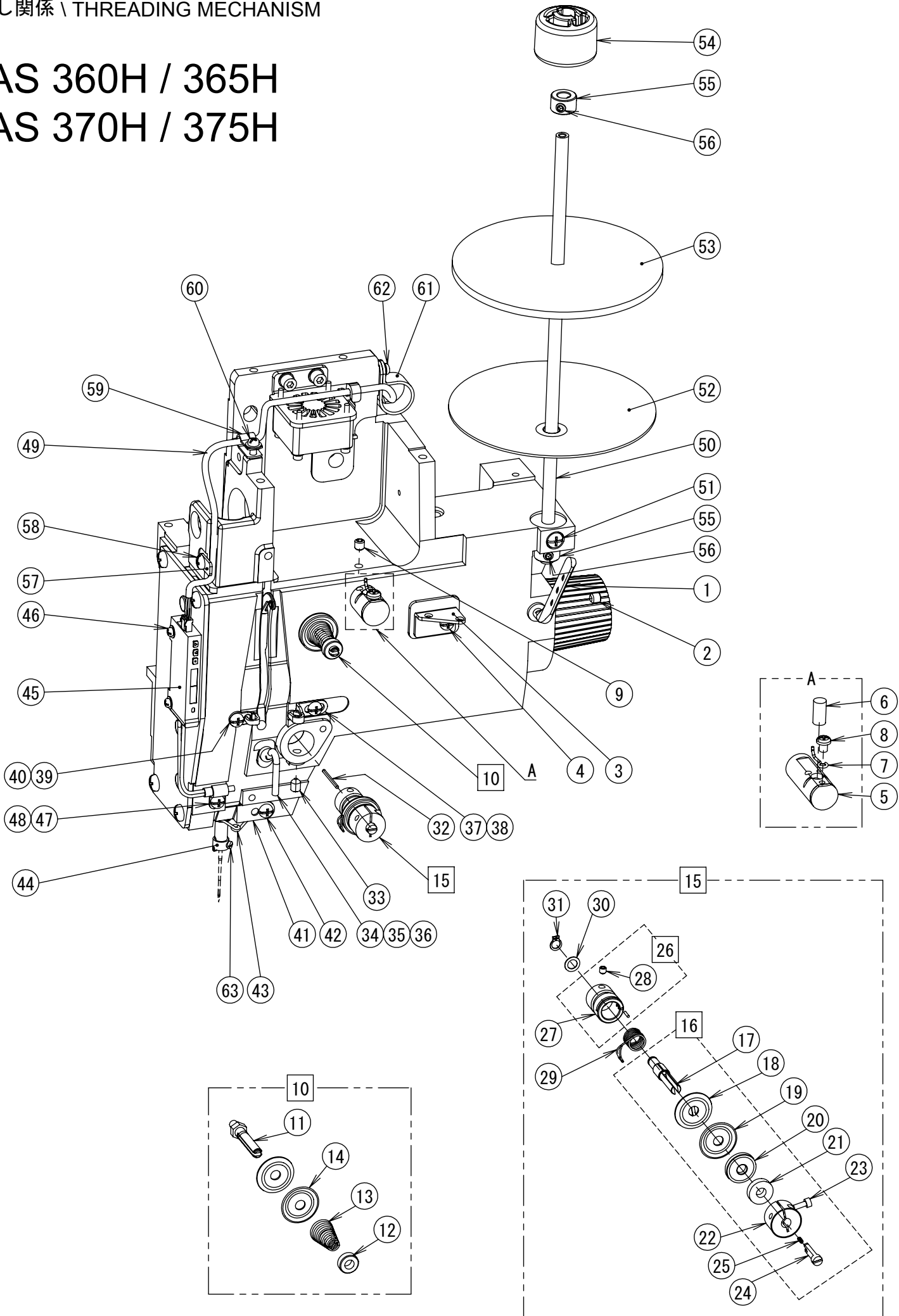

BAS 360H / 365H

H.系通し関係 / THREADING MECHANISM

BAS 370H / 375H

Ref. No.	Code	Q'ty	品名	Part Name
1	SA2636001	1	ミツメイトカケ	THREAD RETAINER
2	012060636	1	アナヒラ6X6	SET SCREW SOCKET (FT) M6X6
3	SA3250001	1	ア-ムイトミチA	ARM THREAD GUIDE,A
4	062500616	1	ナベコ5X6	SCREW PAN M5X6
5	152881101	1	エキレイタイクミ	NEEDLE COOLER ASSY
6	152883000	1	フェルト8X15.5	FELT, 8X15.5
7	152884001	1	エキレイイトカケ	NEEDLE COOLER THREAD GUIDE
8	062670412	1	ナベコ357-40X4	SCREW PAN SM3.57-40X4
9	012060636	1	アナヒラ6X6	SET SCREW SOCKET (FT) M6X6
10	SB6567001	1	プレテンションクミB	PRE-TENSION ASSY B
11	SA3256001	1	イトチヨウシボウA	TENSION STUD A
12	100136001	1	イトチヨウシナツト	TENSION NUT
13	SA4146101	1	フクチヨウシバネ	SUB TENSION SPRING
14	145446002	2	イトチヨウシサラ	DISC TENSION
15	SB6468102	1	DTイトチヨウシクミ	D TENSION ASSY
16	SB6469101	1	DTイトチヨウシボウクミ	D TENSION STUD ASSY
17	SB6433001	1	DTイトチヨウシボウ	D TENSION STUD
18	SA6190001	1	DTイトチヨウシサラ	DISC DT
19	145446002	1	イトチヨウシサラ	DISC TENSION
20	SB1281001	1	テーパサラオサエ	TAPER DISC PRESSER
21	SB1181101	1	DTクッション	DT CUSHION
22	SB1088101	1	セットカラ-DT	SET COLLAR DT
23	018301036	1	アナボルト3X10	BOLT SOCKET M3X10
24	SB1180201	1	キリワリジク	SHAFT
25	SB1267001	1	コイルバネ	COIL SPRING
26	SB1182101	1	DTイトチヨウシダイクミ	TENSION BRACKET ASSY
27	SB1083101	1	DTイトチヨウシダイ	DT TENSION BRACKET
28	012400436	1	アナヒラ4X4	SET SCREW SOCKET (FT) M4X4
29	SA6193301	1	イトトリバネ	THREAD TAKE-UP SPRING
30	109763022	1	ザガネ	WASHER
31	048060142	1	トメワジクヨウC6	RETAINING RING EXTERNAL C6
32	SB6264001	1	ピン1.8X25	PIN 1.8X25
33	SA4143001	1	アナトメネジ6	SET SCREW, (FT) M6X6
34	SA8691001	1	ア-ムイトカケ	THREAD GUIDE ARM
35	021400306	1	3シュナツト4	NUT 3 M4
36	SA9207001	1	ゴムカバー	RUBBER COVER
37	SA6391001	1	ア-ムイトミチC	ARM THREAD GUIDE C
38	062501016	1	ナベコ5X10	SCREW PAN M5X10
39	SA4333001	1	ア-ムイトミチB	ARM THREAD GUIDE,B
40	062501016	1	ナベコ5X10	SCREW PAN M5X10
41	152869001	1	ア-ムイトミチ	ARM THREAD GUIDE
42	062500616	1	ナベコ5X6	SCREW PAN M5X6
43	SA3258001	1	ハリボウメタルDイトアンナイ	N-BAR BUSH THREAD GUIDE,D
44	SA3257101	1	ハリボウイトアンナイA	NEEDLE BAR THREAD GUIDE,A
45	SB8174001	1	ファイバアンプクミ	FIBER AMP ASSY
46	0A5301605	2	+ナベザクミ3X16DB	SCREW PAN (S/P WASHER) M3X16
47	SA5194001	1	センサトリツケイタ	SENSOR SETTING PLATE
48	062501016	1	ナベコ5X10	SCREW PAN M5X10
49	SB8035001	1	アンプケーブルクミ	AMP CABLE ASSY
50	SB8031001	1	イトコマジク	THREAD SPOOL SHAFT
51	062061016	2	ナベコ6X10	SCREW PAN M6X10
52	SB8030001	1	イトコマダイ	THREAD SPOOL STAND BASE
53	150182000	1	スプールマット	SPOOL MAT
54	SB8032001	1	イトコマオサエ	THREAD SPOOL PRESSER
55	SB8607001	2	セットカラー	SET SCREW COLLAR