

N. 穿线装置 / Threading mechanism

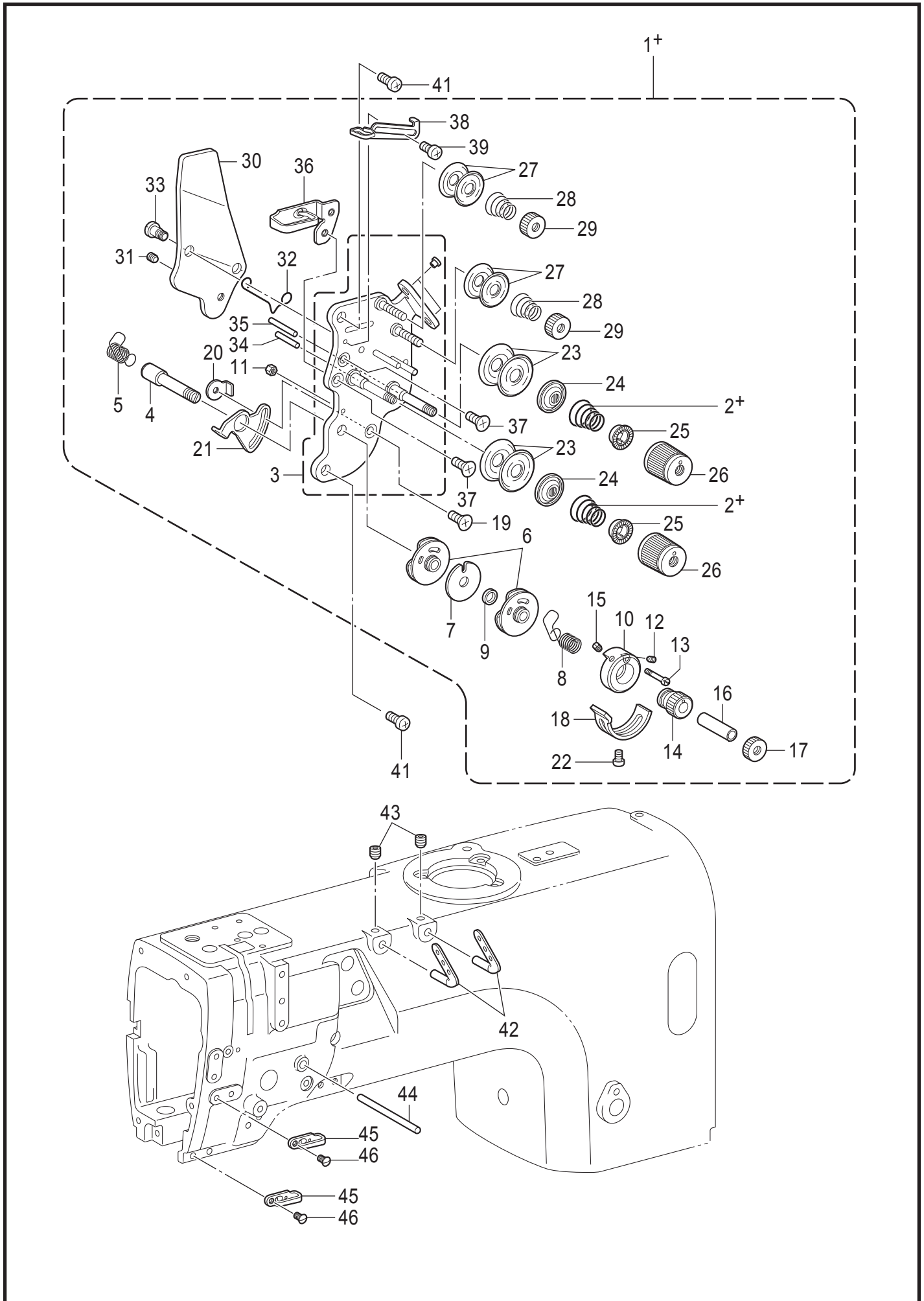

## N. 穿线装置 / Threading mechanism

参照号	零部件序号	数量	零部件名称	NAME OF PARTS	RM
1+	SA3417501	1	<用于-403> 面线调节组件 -3	<For -403> UPPER THREAD TENSION ASSY -3	
2+	SA3415001	2	弹簧 L	TENSION SPRING, L	
1+	SA2607501	1	<用于-405> 面线调节组件 -5	<For -405> UPPER THREAD TENSION ASSY -5	
2+	SA3416101	2	弹簧 LL	TENSION SPRING LL	
3	SA4212001	1	调整台组件	TENSION PLATE ASSY	
4	SA2613101	1	调整短轴	TENSION STUD	
5	SA2614201	1	弹簧 L	THREAD TAKE-UP SPRING L	
6	SA2615001	2	导向组件	GUIDE ASSY, T/TAKE-UP SPRING	
7	SA2619001	1	垫片	SPACER	
8	SA2623201	1	弹簧 R	THREAD TAKE-UP SPRING R	
9	SA2620001	1	轴套	COLLAR	
10	SA2621001	1	定位圈	STOPPER SUPPORT	
11	021300106	1	螺母 M3	NUT 1 M3	
12	SA2626001	1	螺钉 M3.5	SET SCREW (CP) M3.5	
13	SA2624001	1	固定螺栓	SPRING GUIDE SET SCREW	
14	SA2625001	1	调节旋钮	ADJUSTING THUMB	
15	SA2626001	1	螺钉 M3.5	SET SCREW (CP) M3.5	
16	SA2627001	1	轴套	COLLAR	
17	SA2628001	1	调线螺母	TENSION NUT	
18	SA2629001	1	弹簧限位板	STOPPER	
19	004350616	1	螺钉 M3.5X6	SCREW FLAT M3.5X6	
20	SA2824001	1	定位螺母 M3.5	NUT, WHIRL-STOP M3.5	
21	SA2630001	1	限位板	STOPPER	
22	062350516	1	螺钉 M3.5X5	SCREW PAN M3.5X5	
23	145446002	4	夹线盘	DISC TENSION	
24	159805001	2	夹线压盘	TENSION DISC PRESSER	
25	S20681000	2	调节弹簧垫圈	WASHER	
26	S20682111	2	夹线螺母	TENSION NUT	
27	144504001	4	导向盘	THREAD GUIDE DISC	
28	154560101	2	小夹线弹簧 A	PRE-TENSION SPRING A	
29	155510001	2	夹线螺母	TENSION NUT	
30	SA2632001	1	松线板	TENSION RELEASE PLATE	
31	012500536	1	螺钉 M5X5	SET SCREW SOCKET (FT) M5X5	
32	S38274001	1	松线弹簧	T-RELEASE SPRING	
33	SA2633001	2	轴位螺钉 M3.5	SHOULDER SCREW M3.5	
34	SA4506001	1	松线销 L	TENSION RELEASE PIN, L	
35	SA4507001	1	松线销 R	TENSION RELEASE PIN, R	
36	SA2634001	1	线导向 U	THREAD GUIDE, U: ARM	
37	004350616	2	螺钉 M3.5X6	SCREW FLAT M3.5X6	
38	SA2635001	1	线调整	THREAD QUANTITY ADJUST	
39	062300616	1	螺钉 M3X6	SCREW PAN M3X6	
41	062500816	2	螺钉 M5X8	SCREW PAN M5X8	
42	SA2636001	2	三眼线勾	THREAD RETAINER	
43	012060636	2	螺钉 M6X6	SET SCREW SOCKET (FT) M6X6	
44	SA2637001	1	松线轴	BAR, TENSION RELEASE	
45	SA2638001	2	线导向 M	THREAD GUIDE, M: ARM	
46	SA2640001	2	螺钉 M5X8	SCREW FLAT M5X8	



REF.NO	CODE	Q'TY	品名	NAME OF PARTS	RM
			<-003用>	<For -003>	
1+	SA3417401	1	ウワイトチヨウシクミ-3	UPPER THREAD TENSION ASSY -3	
2+	SA3415001	2	イトチヨウシバネL	TENSION SPRING, L	
			<-005用>	<For -005>	
1+	SA2607401	1	ウワイトチヨウシクミ-5	UPPER THREAD TENSION ASSY -5	
2+	SA3416101	2	イトチヨウシバネLL	TENSION SPRING LL	
3	SA4212001	1	イトチヨウシダイクミ	TENSION PLATE ASSY	
4	SA2613001	1	チヨウシジク	TENSION STUD	
5	SA2614201	1	イトトリバネL	THREAD TAKE-UP SPRING L	
6	SA2615001	2	イトトリバネアンナイクミ	GUIDE ASSY, T/TAKE-UP SPRING	
7	SA2619001	1	スペーサー	SPACER	
8	SA2623201	1	イトトリバネR	THREAD TAKE-UP SPRING R	
9	SA2620001	1	カラ-	COLLAR	
10	SA2621001	1	ストツパウケ	STOPPER SUPPORT	
11	021300106	1	1シュナット3	NUT 1 M3	
12	SA2626001	1	トメネジ3.5	SET SCREW, (CP) M3.5	
13	SA2624001	1	バネアンナイトメネジ	SPRING GUIDE SET SCREW	
14	SA2625001	1	チヨウセツツマミ	ADJUSTING THUMB	
15	SA2626001	1	トメネジ3.5	SET SCREW, (CP) M3.5	
16	SA2627001	1	カラ-	COLLAR	
17	SA2628001	1	イトチヨウシナット	TENSION NUT	
18	SA2629001	1	イトトリバネストツパ	STOPPER	
19	004350616	1	+サラコ3.5X6	SCREW FLAT M3.5X6	
20	SA2824001	1	マワリドメナツトM3.5	NUT, WHIRL-STOP M3.5	
21	SA2630001	1	イトトリバネストツパ	STOPPER	
22	062350516	1	ナベコ35X5	SCREW PAN M3.5X5	
23	145446001	4	イトチヨウシサラ	DISC, TENSION	
24	159805001	2	イトチヨウシサラオサエ	TENSION DISC PRESSER	
25	S20681000	2	チヨウシバネウエザガネ	WASHER	
26	S20682111	2	イトチヨウシナット	TENSION NUT	
27	144504001	4	イトアンナイサラ	THREAD GUIDE DISC	
28	154560101	2	プレテンションバネA	PRE-TENSION SPRING A	
29	155510001	2	イトチヨウシナット	TENSION NUT	
30	SA2632001	1	イトユルメイタ	TENSION RELEASE PLATE	
31	012500536	1	アナヒラ5X5	SET SCREW SOCKET (FT) M5X5	
32	S38274001	1	イトユルメバネ	T-RELEASE SPRING	
33	SA2633001	2	ダンネジ3.5	SHOULDER SCREW, M3.5	
34	SA4506001	1	イトユルメピンL	TENSION RELEASE PIN, L	
35	SA4507001	1	イトユルメピンR	TENSION RELEASE PIN, R	
36	SA2634001	1	ア-ムイトアンナイU	THREAD GUIDE, U :ARM	
37	004350616	2	+サラコ3.5X6	SCREW FLAT M3.5X6	
38	SA2635001	1	イトリヨウチヨウセイ	THREAD QUANTITY ADJUST	
39	062300616	1	ナベコ3X6	SCREW PAN M3X6	
40	SA6378001	1	キャツブ	CAP	
41	SA2639001	1	ア-ムイトアンナイD	THREAD GUIDE, D :ARM	
42	114941001	1	ア-ムイトアンナイフェルト	FELT	
43	062500816	2	ナベコ5X8	SCREW PAN M5X8	
44	SA2636001	2	ミツメイトカケ	THREAD RETAINER	
45	012060636	2	アナヒラ6X6	SET SCREW SOCKET (FT) M6X6	
46	SA2637001	1	イトユルメジク	BAR, TENSION RELEASE	
47	SA2638001	1	ア-ムイトアンナイM	THREAD GUIDE, M :ARM	
48	SA2640001	2	サラネジ5X8	SCREW FLAT M5X8	

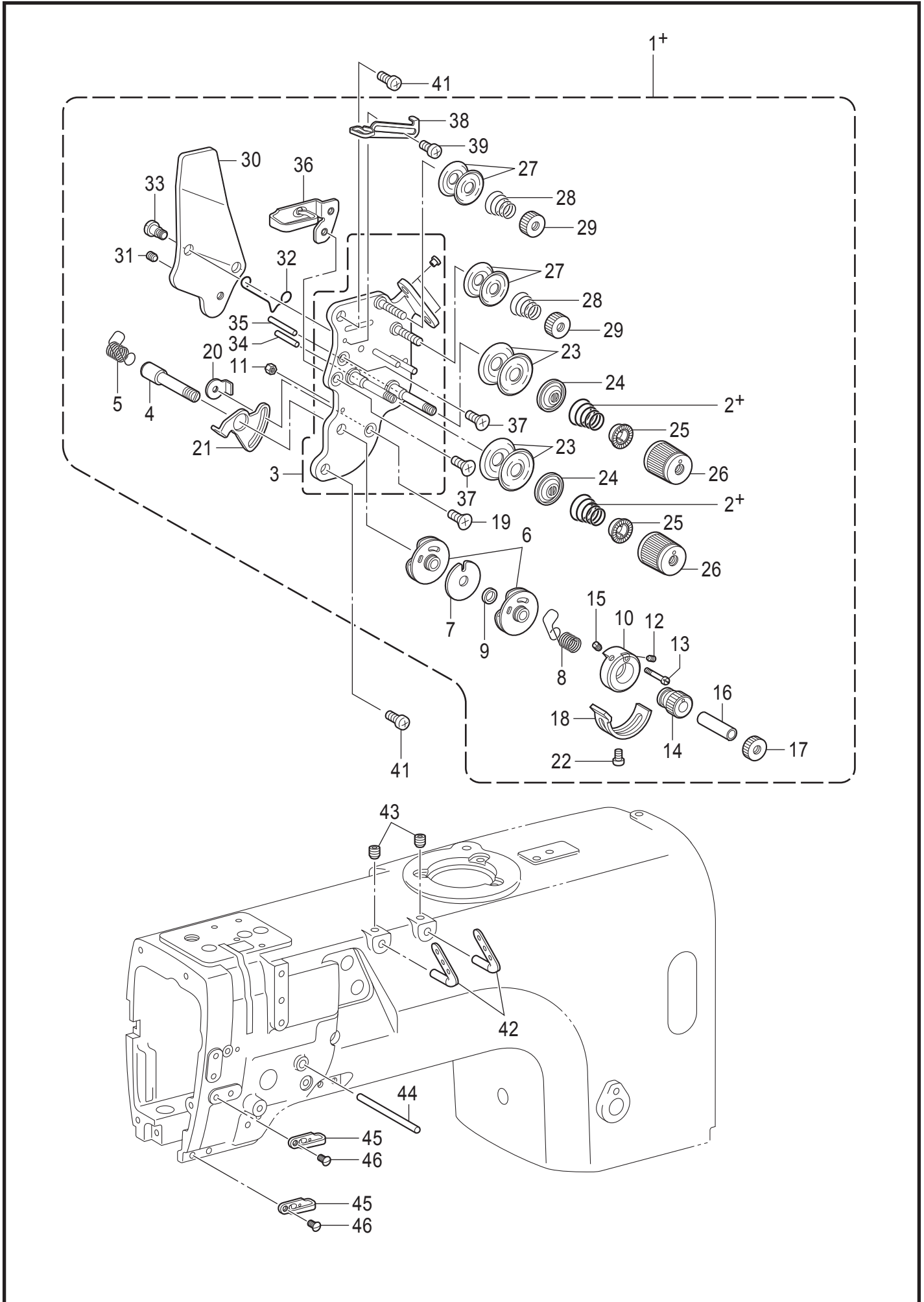

## N. 糸通し関係 / Threading mechanism

REF.NO	CODE	Q'TY	品名	NAME OF PARTS	RM
			<-403用>	<For -403>	
1+	SA3417501	1	ウワイトチヨウシクミ-3	UPPER THREAD TENSION ASSY -3	
2+	SA3415001	2	イトチヨウシバネL	TENSION SPRING, L	
			<-405, -407用>	<For -405, -407>	
1+	SA2607501	1	ウワイトチヨウシクミ-5	UPPER THREAD TENSION ASSY -5	
2+	SA3416101	2	イトチヨウシバネLL	TENSION SPRING LL	
3	SA4212001	1	イトチヨウシダイクミ	TENSION PLATE ASSY	
4	SA2613101	1	チヨウシジク	TENSION STUD	
5	SA2614201	1	イトトリバネL	THREAD TAKE-UP SPRING L	
6	SA2615001	2	イトトリバネアンナイクミ	GUIDE ASSY, T/TAKE-UP SPRING	
7	SA2619001	1	スペーサー	SPACER	
8	SA2623201	1	イトトリバネR	THREAD TAKE-UP SPRING R	
9	SA2620001	1	カラ-	COLLAR	
10	SA2621001	1	ストツパウケ	STOPPER SUPPORT	
11	021300106	1	1シュナット3	NUT 1 M3	
12	SA2626001	1	トメネジ3.5	SET SCREW (CP) M3.5	
13	SA2624001	1	バネアンナイトメネジ	SPRING GUIDE SET SCREW	
14	SA2625001	1	チヨウセツツマミ	ADJUSTING THUMB	
15	SA2626001	1	トメネジ3.5	SET SCREW (CP) M3.5	
16	SA2627001	1	カラ-	COLLAR	
17	SA2628001	1	イトチヨウシナット	TENSION NUT	
18	SA2629001	1	イトトリバネストツパ	STOPPER	
19	004350616	1	+サラコ3.5X6	SCREW FLAT M3.5X6	
20	SA2824001	1	マワリドメナットM3.5	NUT, WHIRL-STOP M3.5	
21	SA2630001	1	イトトリバネストツパ	STOPPER	
22	062350516	1	ナベコ35X5	SCREW PAN M3.5X5	
23	145446002	4	イトチヨウシサラ	DISC TENSION	
24	159805001	2	イトチヨウシサラオサエ	TENSION DISC PRESSER	
25	S20681000	2	チヨウシバネウエザガネ	WASHER	
26	S20682111	2	イトチヨウシナット	TENSION NUT	
27	144504001	4	イトアンナイサラ	THREAD GUIDE DISC	
28	154560101	2	プレテンションバネA	PRE-TENSION SPRING A	
29	155510001	2	イトチヨウシナット	TENSION NUT	
30	SA2632001	1	イトユルメイタ	TENSION RELEASE PLATE	
31	012500536	1	アナヒラ5X5	SET SCREW SOCKET (FT) M5X5	
32	S38274001	1	イトユルメバネ	T-RELEASE SPRING	
33	SA2633001	2	ダンネジ3.5	SHOULDER SCREW M3.5	
34	SA4506001	1	イトユルメピンL	TENSION RELEASE PIN, L	
35	SA4507001	1	イトユルメピンR	TENSION RELEASE PIN, R	
36	SA2634001	1	ア-ムイトアンナイU	THREAD GUIDE, U: ARM	
37	004350616	2	+サラコ3.5X6	SCREW FLAT M3.5X6	
38	SA2635001	1	イトリヨウチヨウセイ	THREAD QUANTITY ADJUST	
39	062300616	1	ナベコ3X6	SCREW PAN M3X6	
41	062500816	2	ナベコ5X8	SCREW PAN M5X8	
42	SA2636001	2	ミツメイトカケ	THREAD RETAINER	
43	012060636	2	アナヒラ6X6	SET SCREW SOCKET (FT) M6X6	
44	SA2637001	1	イトユルメジク	BAR, TENSION RELEASE	
45	SA2638001	2	ア-ムイトアンナイM	THREAD GUIDE, M: ARM	
46	SA2640001	2	サラネジ5X8	SCREW FLAT M5X8	

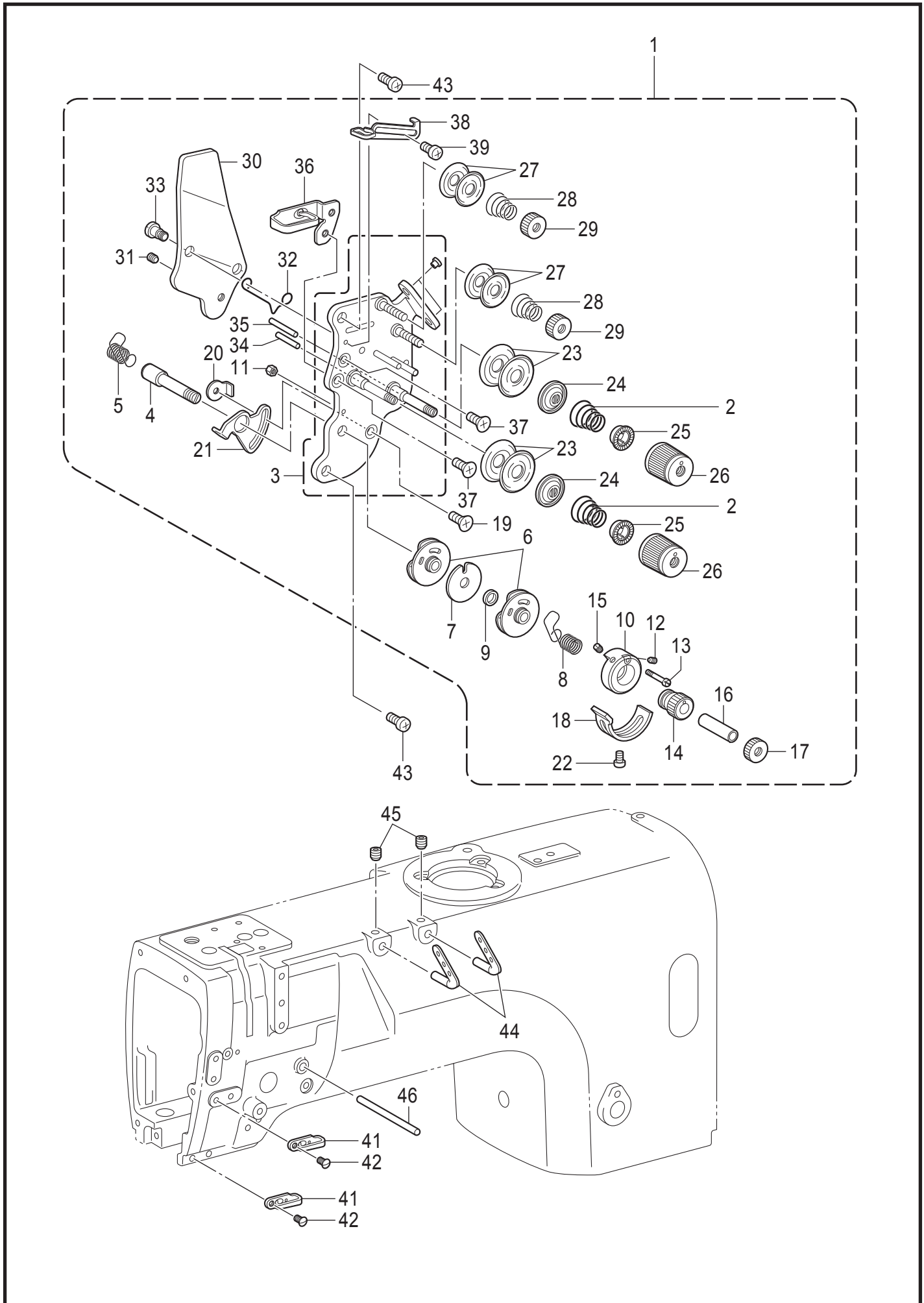



## M. 糸通し関係 / Threading mechanism

REF.NO	CODE	Q'TY	品名	NAME OF PARTS	RM
1	SA2607501	1	ウワイトチヨウシクミ-5	UPPER THREAD TENSION ASSY -5	
2	SA3416101	2	イトチヨウシバネLL	TENSION SPRING LL	
3	SA4212001	1	イトチヨウシダイクミ	TENSION PLATE ASSY	
4	SA2613101	1	チヨウシジク	TENSION STUD	
5	SA2614201	1	イトトリバネL	THREAD TAKE-UP SPRING L	
6	SA2615001	2	イトトリバネアンナイクミ	GUIDE ASSY, T/TAKE-UP SPRING	
7	SA2619001	1	スペーサー	SPACER	
8	SA2623201	1	イトトリバネR	THREAD TAKE-UP SPRING R	
9	SA2620001	1	カラ-	COLLAR	
10	SA2621001	1	ストツパウケ	STOPPER SUPPORT	
11	021300106	1	1シュナツ3	NUT 1 M3	
12	SA2626001	1	トメネジ3.5	SET SCREW (CP) M3.5	
13	SA2624001	1	バネアンナイトメネジ	SPRING GUIDE SET SCREW	
14	SA2625001	1	チヨウセツツマミ	ADJUSTING THUMB	
15	SA2626001	1	トメネジ3.5	SET SCREW (CP) M3.5	
16	SA2627001	1	カラ-	COLLAR	
17	SA2628001	1	イトチヨウシナツト	TENSION NUT	
18	SA2629001	1	イトトリバネストツパ	STOPPER	
19	004350616	1	+サラコ3.5X6	SCREW FLAT M3.5X6	
20	SA2824001	1	マワリドメナツトM3.5	NUT, WHIRL-STOP M3.5	
21	SA2630001	1	イトトリバネストツパ	STOPPER	
22	062350516	1	ナベコ35X5	SCREW PAN M3.5X5	
23	145446002	4	イトチヨウシサラ	DISC TENSION	
24	159805001	2	イトチヨウシサラオサエ	TENSION DISC PRESSER	
25	S20681000	2	チヨウシバネウエザガネ	WASHER	
26	S20682111	2	イトチヨウシナツト	TENSION NUT	
27	144504001	4	イトアンナイサラ	THREAD GUIDE DISC	
28	154560101	2	プレテンションバネA	PRE-TENSION SPRING A	
29	155510001	2	イトチヨウシナツト	TENSION NUT	
30	SA2632001	1	イトユルメイタ	TENSION RELEASE PLATE	
31	012500536	1	アナヒラ5X5	SET SCREW SOCKET (FT) M5X5	
32	S38274001	1	イトユルメバネ	T-RELEASE SPRING	
33	SA2633001	2	ダンネジ3.5	SHOULDER SCREW M3.5	
34	SA4506001	1	イトユルメピンL	TENSION RELEASE PIN, L	
35	SA4507001	1	イトユルメピンR	TENSION RELEASE PIN, R	
36	SA2634001	1	ア-ムイトアンナイU	THREAD GUIDE, U :ARM	
37	004350616	2	+サラコ3.5X6	SCREW FLAT M3.5X6	
38	SA2635001	1	イトリヨウチヨウセイ	THREAD QUANTITY ADJUST	
39	062300616	1	ナベコ3X6	SCREW PAN M3X6	
41	SA2638001	2	ア-ムイトアンナイM	THREAD GUIDE, M :ARM	
42	SA2640001	2	サラネジ5X8	SCREW FLAT M5X8	
43	062500816	2	ナベコ5X8	SCREW PAN M5X8	
44	SA2636001	2	ミツメイトカケ	THREAD RETAINER	
45	012060636	2	アナヒラ6X6	SET SCREW SOCKET (FT) M6X6	
46	SA2637001	1	イトユルメジク	BAR, TENSION RELEASE	



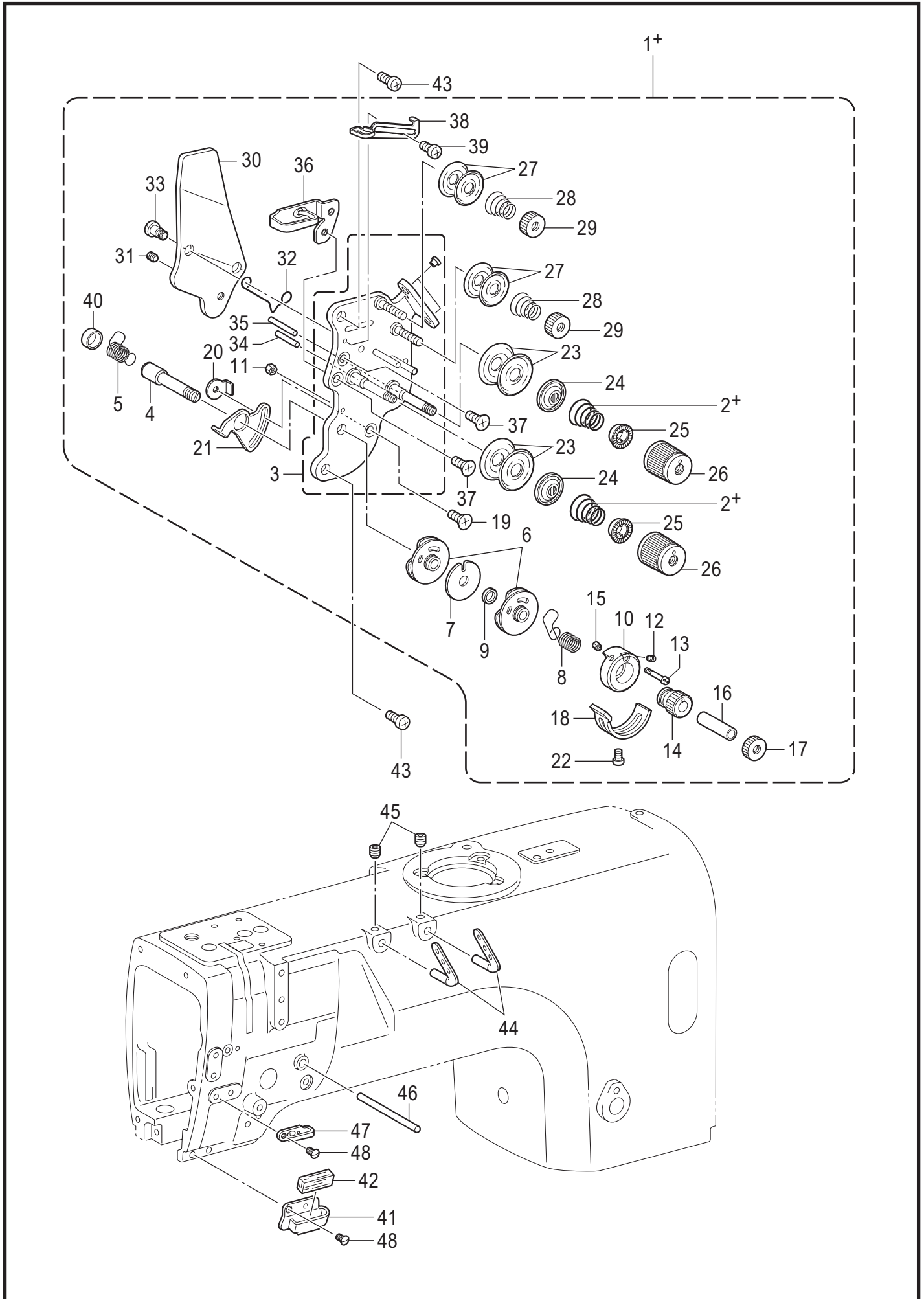

## L. 糸通し関係 / Threading mechanism

REF.NO	CODE	Q'TY	品名	NAME OF PARTS	RM
			<-0□3用>	<For -0□3>	
1+	SA3417401	1	ウワイトチヨウシクミ-3	UPPER THREAD TENSION ASSY, -3	
2+	SA3415001	2	イトチヨウシバナL	TENSION SPRING, L	
			<-005用>	<For -005>	
1+	SA2607401	1	ウワイトチヨウシクミ-5	UPPER THREAD TENSION ASSY, -5	
2+	SA3416101	2	イトチヨウシバナLL	TENSION SPRING LL	
			<-03F用>	<For -03F>	
1+	SA2818401	1	ウワイトチヨウシクミ-1	UPPER THREAD TENSION ASSY, -1	
2+	SA3414101	2	イトチヨウシバナM	TENSION SPRING M	
3	SA4212001	1	イトチヨウシダイクミ	TENSION PLATE ASSY	
4	SA2613001	1	チヨウシジク	TENSION STUD	
5	SA2614201	1	イトトリバナL	THREAD TAKE-UP SPRING, L	
6	SA2615001	2	イトトリバナアンナイクミ	GUIDE ASSY, T/TAKE-UP SPRING	
7	SA2619001	1	スペーサー	SPACER	
8	SA2623201	1	イトトリバナR	THREAD TAKE-UP SPRING, R	
9	SA2620001	1	カラ-	COLLAR	
10	SA2621001	1	ストツパウケ	STOPPER SUPPORT	
11	021300106	1	1シュナツ3	NUT 1 M3	
12	SA2626001	1	トメネジ3.5	SET SCREW, (CP) M3.5	
13	SA2624001	1	バネアンナイトメネジ	SPRING GUIDE SET SCREW	
14	SA2625001	1	チヨウセツツマミ	ADJUSTING THUMB	
15	SA2626001	1	トメネジ3.5	SET SCREW, (CP) M3.5	
16	SA2627001	1	カラ-	COLLAR	
17	SA2628001	1	イトチヨウシナツト	TENSION NUT	
18	SA2629001	1	イトトリバナストツパ	STOPPER	
19	004350616	1	+サラコ3.5X6	SCREW FLAT M3.5X6	
20	SA2824001	1	マワリドメナツトM3.5	NUT, WHIRL-STOP M3.5	
21	SA2630001	1	イトトリバナストツパ	STOPPER	
22	062350516	1	ナベコ35X5	SCREW PAN M3.5X5	
23	145446001	4	イトチヨウシサラ	DISC, TENSION	
24	159805001	2	イトチヨウシサラオサエ	TENSION DISC PRESSER	
25	S20681000	2	チヨウシバナウエザガネ	WASHER	
26	S20682111	2	イトチヨウシナツト	TENSION NUT	
27	144504001	4	イトアンナイサラ	THREAD GUIDE DISC	
28	154560101	2	プレテンションバネA	PRE-TENSION SPRING A	
29	155510001	2	イトチヨウシナツト	TENSION NUT	
30	SA2632001	1	イトユルメイタ	TENSION RELEASE PLATE	
31	012500536	1	アナヒラ5X5	SET SCREW SOCKET (FT) M5X5	
32	S38274001	1	イトユルメバネ	T-RELEASE SPRING	
33	SA2633001	2	ダンネジ3.5	SHOULDER SCREW, M3.5	
34	SA4506001	1	イトユルメピンL	TENSION RELEASE PIN, L	
35	SA4507001	1	イトユルメピンR	TENSION RELEASE PIN, R	
36	SA2634001	1	ア-ムイトアンナイU	THREAD GUIDE, U: ARM	
37	004350616	2	+サラコ3.5X6	SCREW FLAT M3.5X6	
38	SA2635001	1	イトリヨウチヨウセイ	THREAD QUANTITY ADJUST	
39	062300616	1	ナベコ3X6	SCREW PAN M3X6	
40	SA6378001	1	キャツブ	CAP	
41	SA2639001	1	ア-ムイトアンナイD	THREAD GUIDE, D: ARM	
42	114941001	1	ア-ムイトアンナイフェルト	FELT	
43	062500816	2	ナベコ5X8	SCREW PAN M5X8	
44	SA2636001	2	ミツメイトカケ	THREAD RETAINER	
45	012060636	2	アナヒラ6X6	SET SCREW SOCKET (FT) M6X6	
46	SA2637001	1	イトユルメジク	BAR, TENSION RELEASE	
47	SA2638001	1	ア-ムイトアンナイM	THREAD GUIDE, M: ARM	
48	SA2640001	2	サラネジ5X8	SCREW FLAT M5X8	

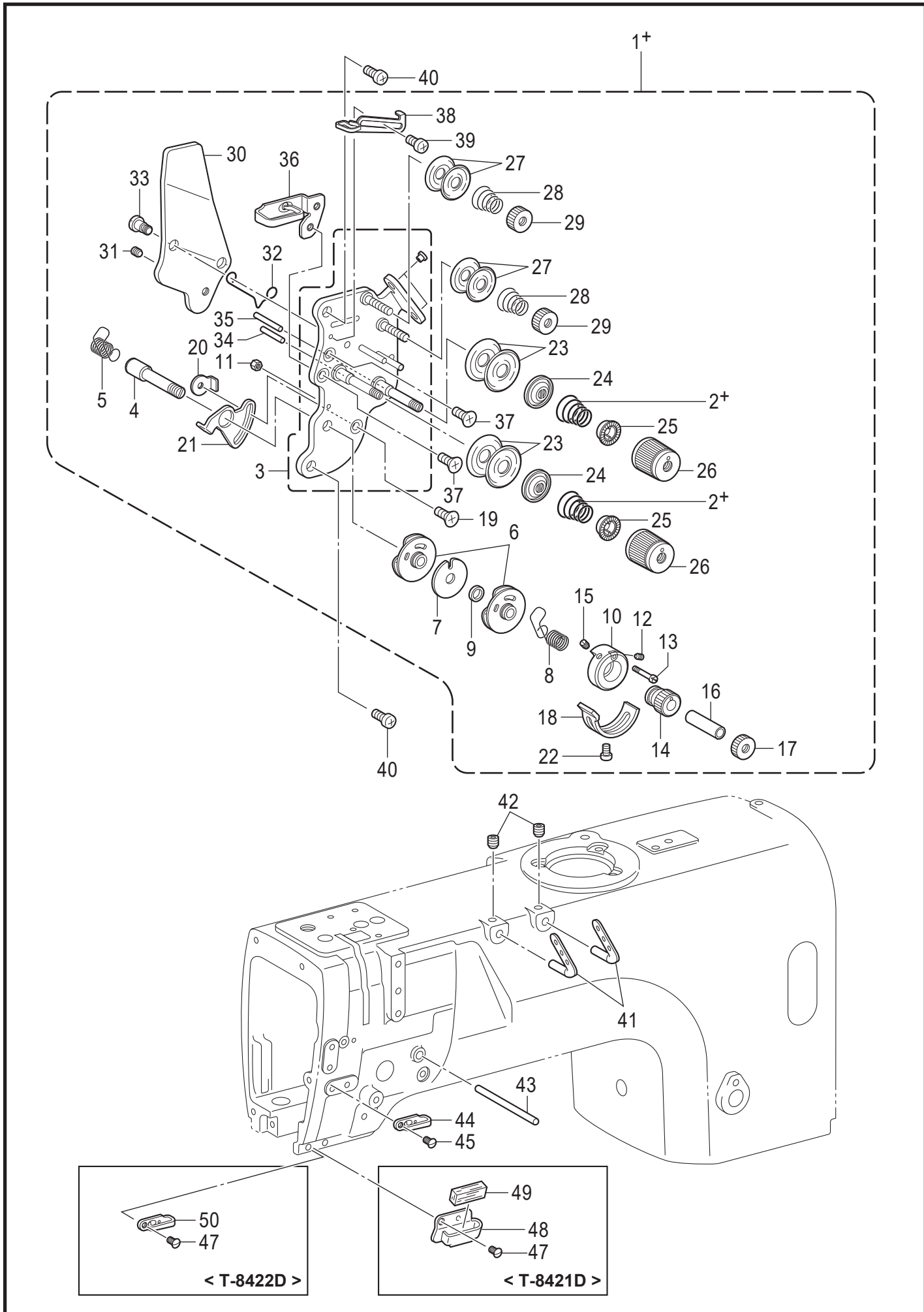

REF.NO	CODE	Q'TY	品名	NAME OF PARTS	RM
1+	SA3417501	1	<-□03用> ウワイトチヨウシクミ-3	<For -□03> UPPER THREAD TENSION ASSY -3	
2+	SA3415001	2	イトチヨウシバネL	TENSION SPRING, L	
1+	SA2607501	1	<-□05,-S07用> ウワイトチヨウシクミ-5	<For -□05,-S07> UPPER THREAD TENSION ASSY -5	
2+	SA3416101	2	イトチヨウシバネLL	TENSION SPRING LL	
1+	SA2818501	1	<-T□F用> ウワイトチヨウシクミ-1	<For -T□F> UPPER THREAD TENSION ASSY -1	
2+	SA3414101	2	イトチヨウシバネM	TENSION SPRING M	
3	SA4212001	1	イトチヨウシダイクミ	TENSION PLATE ASSY	
4	SA2613101	1	チヨウシジク	TENSION STUD	
5	SA2614201	1	イトトリバネL	THREAD TAKE-UP SPRING L	
6	SA2615001	2	イトトリバネアンナイクミ	GUIDE ASSY, T/TAKE-UP SPRING	
7	SA2619001	1	スペーサー	SPACER	
8	SA2623201	1	イトトリバネR	THREAD TAKE-UP SPRING R	
9	SA2620001	1	カラ-	COLLAR	
10	SA2621001	1	ストツパウケ	STOPPER SUPPORT	
11	021300106	1	1シュナット3	NUT 1 M3	
12	SA2626001	1	トメネジ3.5	SET SCREW (CP) M3.5	
13	SA2624001	1	バネアンナイトメネジ	SPRING GUIDE SET SCREW	
14	SA2625001	1	チヨウセツツマミ	ADJUSTING THUMB	
15	SA2626001	1	トメネジ3.5	SET SCREW (CP) M3.5	
16	SA2627001	1	カラ-	COLLAR	
17	SA2628001	1	イトチヨウシナット	TENSION NUT	
18	SA2629001	1	イトトリバネストツパ	STOPPER	
19	004350616	1	+サラコ3.5X6	SCREW FLAT M3.5X6	
20	SA2824001	1	マワリドメナットM3.5	NUT, WHIRL-STOP M3.5	
21	SA2630001	1	イトトリバネストツパ	STOPPER	
22	062350516	1	ナベコ35X5	SCREW PAN M3.5X5	
23	145446002	4	イトチヨウシサラ	DISC TENSION	
24	159805001	2	イトチヨウシサラオサエ	TENSION DISC PRESSER	
25	S20681000	2	チヨウシバネウエザガネ	WASHER	
26	S20682111	2	イトチヨウシナット	TENSION NUT	
27	144504001	4	イトアンナイサラ	THREAD GUIDE DISC	
28	154560101	2	プレテンションバネA	PRE-TENSION SPRING A	
29	155510001	2	イトチヨウシナット	TENSION NUT	
30	SA2632001	1	イトユルメイタ	TENSION RELEASE PLATE	
31	012500536	1	アナヒラ5X5	SET SCREW SOCKET (FT) M5X5	
32	S38274001	1	イトユルメバネ	T-RELEASE SPRING	
33	SA2633001	2	ダンネジ3.5	SHOULDER SCREW M3.5	
34	SA4506001	1	イトユルメピンL	TENSION RELEASE PIN, L	
35	SA4507001	1	イトユルメピンR	TENSION RELEASE PIN, R	
36	SA2634001	1	ア-ムイトアンナイU	THREAD GUIDE, U: ARM	
37	004350616	2	+サラコ3.5X6	SCREW FLAT M3.5X6	
38	SA2635001	1	イトリヨウチヨウセイ	THREAD QUANTITY ADJUST	
39	062300616	1	ナベコ3X6	SCREW PAN M3X6	
40	062500816	2	ナベコ5X8	SCREW PAN M5X8	
41	SA2636001	2	ミツメイトカケ	THREAD RETAINER	
42	012060636	2	アナヒラ6X6	SET SCREW SOCKET (FT) M6X6	
43	SA2637001	1	イトユルメジク	BAR, TENSION RELEASE	
44	SA2638001	1	ア-ムイトアンナイM	THREAD GUIDE, M: ARM	
45	SA2640001	1	サラネジ5X8	SCREW FLAT M5X8	
47	SA2640001	1	サラネジ5X8	SCREW FLAT M5X8	
48	SA2639001	1	<T-8421D用> ア-ムイトアンナイD	<For T-8421D> THREAD GUIDE, D: ARM	
49	114941001	1	ア-ムイトアンナイフェルト	FELT	
50	SA2638001	1	<T-8422D用> ア-ムイトアンナイM	<For T-8422D> THREAD GUIDE, M: ARM	

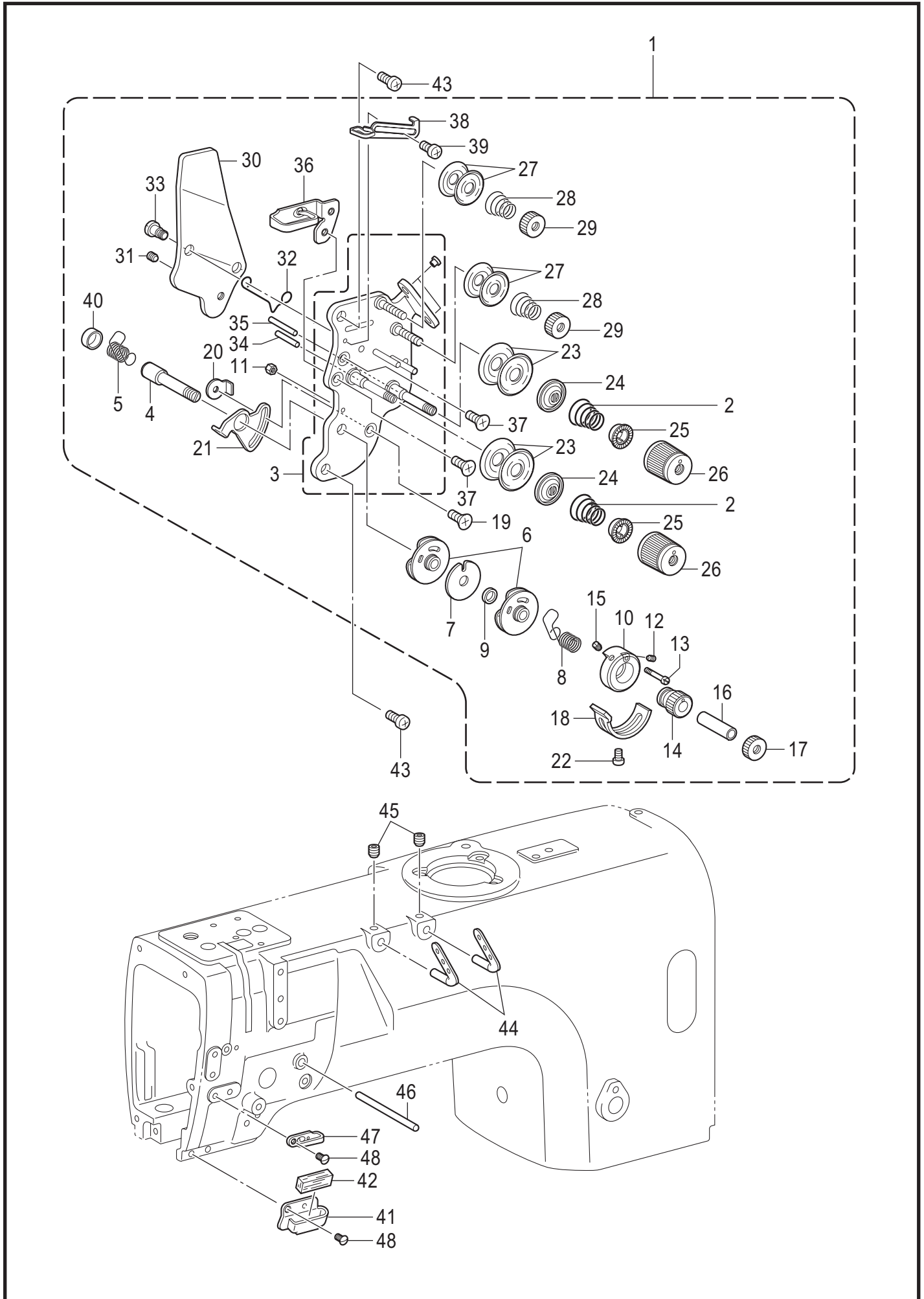

REF.NO	CODE	Q'TY	品名	NAME OF PARTS	RM
1	SA2607401	1	ウワイトチヨウシクミ-5	UPPER THREAD TENSION ASSY, -5	
2	SA3416101	2	イトチヨウシバネLL	TENSION SPRING LL	
3	SA4212001	1	イトチヨウシダイクミ	TENSION PLATE ASSY	
4	SA2613001	1	チヨウシジク	TENSION STUD	
5	SA2614201	1	イトトリバネL	THREAD TAKE-UP SPRING, L	
6	SA2615001	2	イトトリバネアンナイクミ	GUIDE ASSY, T/TAKE-UP SPRING	
7	SA2619001	1	スペーサ-	SPACER	
8	SA2623201	1	イトトリバネR	THREAD TAKE-UP SPRING, R	
9	SA2620001	1	カラ-	COLLAR	
10	SA2621001	1	ストツパウケ	STOPPER SUPPORT	
11	021300106	1	1シュナツト3	NUT 1 M3	
12	SA2626001	1	トメネジ3.5	SET SCREW (CP) M3.5	
13	SA2624001	1	バネアンナイトメネジ	SPRING GUIDE SET SCREW	
14	SA2625001	1	チヨウセツツマミ	ADJUSTING THUMB	
15	SA2626001	1	トメネジ3.5	SET SCREW (CP) M3.5	
16	SA2627001	1	カラ-	COLLAR	
17	SA2628001	1	イトチヨウシナツト	TENSION NUT	
18	SA2629001	1	イトトリバネストツパ	STOPPER	
19	004350616	1	+サラコ3.5X6	SCREW FLAT M3.5X6	
20	SA2824001	1	マワリドメナツトM3.5	NUT, WHIRL-STOP M3.5	
21	SA2630001	1	イトトリバネストツパ	STOPPER	
22	062350516	1	ナベコ35X5	SCREW PAN M3.5X5	
23	145446001	4	イトチヨウシサラ	DISC, TENSION	
24	159805001	2	イトチヨウシサラオサエ	TENSION DISC PRESSER	
25	S20681000	2	チヨウシバネウエザガネ	WASHER	
26	S20682111	2	イトチヨウシナツト	TENSION NUT	
27	144504001	4	イトアンナイサラ	THREAD GUIDE DISC	
28	154560101	2	プレテンションバネA	PRE-TENSION SPRING, A	
29	155510001	2	イトチヨウシナツト	TENSION NUT	
30	SA2632001	1	イトユルメイタ	TENSION RELEASE PLATE	
31	012500536	1	アナヒラ5X5	SET SCREW SOCKET (FT) M5X5	
32	S38274001	1	イトユルメバネ	T-RELEASE SPRING	
33	SA2633001	2	ダンネジ3.5	SHOULDER SCREW, M3.5	
34	SA4506001	1	イトユルメピンL	TENSION RELEASE PIN, L	
35	SA4507001	1	イトユルメピンR	TENSION RELEASE PIN, R	
36	SA2634001	1	ア-ムイトアンナイU	THREAD GUIDE, U: ARM	
37	004350616	2	+サラコ3.5X6	SCREW FLAT M3.5X6	
38	SA2635001	1	イトリヨウチヨウセイ	THREAD QUANTITY ADJUST	
39	062300616	1	ナベコ3X6	SCREW PAN M3X6	
40	SA6378001	1	キャツブ	CAP	
41	SA2639001	1	ア-ムイトアンナイD	THREAD GUIDE, D: ARM	
42	114941001	1	ア-ムイトアンナイフェルト	FELT	
43	062500816	2	ナベコ5X8	SCREW PAN M5X8	
44	SA2636001	2	ミツメイトカケ	THREAD RETAINER	
45	012060636	2	アナヒラ6X6	SET SCREW SOCKET (FT) M6X6	
46	SA2637001	1	イトユルメジク	BAR, TENSION RELEASE	
47	SA2638001	1	ア-ムイトアンナイM	THREAD GUIDE, M: ARM	
48	SA2640001	2	サラネジ5X8	SCREW FLAT M5X8	