

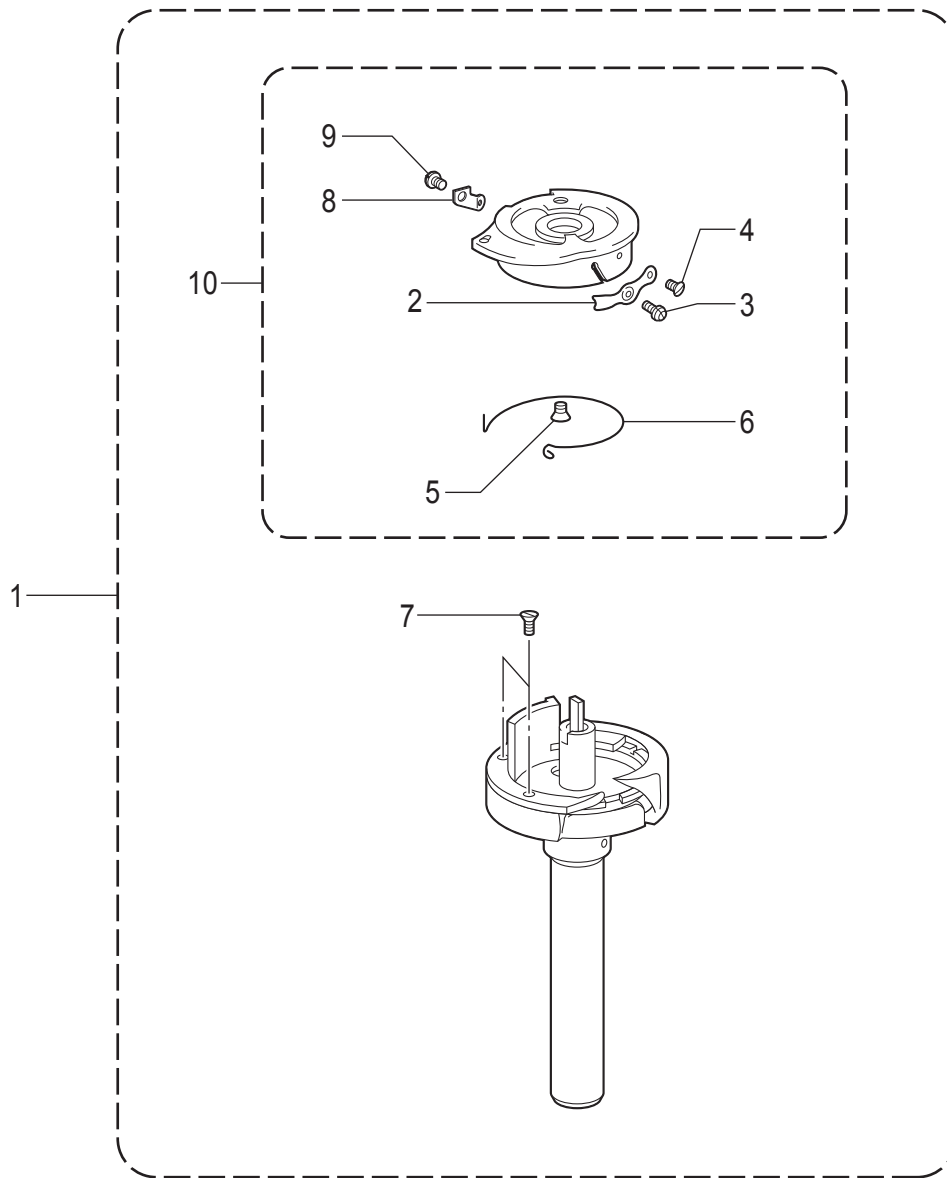

## K2. 旋梭装置 / Rotary hook mechanism

参照号	零部件序号	数量	零部件名称	NAME OF PARTS	RM
1	SA9783001	1	盒装旋梭组件 SA9457	ROTARY HOOK ASSY W/BOX SA9457	
2	151043001	1	夹线簧	TENSION SPRING	
3	S01567001	1	螺钉	TENSION ADJUSTING SCREW	
4	S01568001	1	螺钉	SET SCREW	
5	151035001	1	螺钉	SET SCREW	
6	151034001	1	弹簧	SPRING	
7	151027001	2	螺钉	SET SCREW	
8	159801001	1	压线钢丝	THREAD PRESSER WIRE	
9	SA8266001	1	螺钉 SM1.59X1.6	SCREW SM1.59X1.6	
10	S07742001	1	梭芯套组件	CAP ASSY	

T-8752D



REF.NO	CODE	Q'TY	品名	NAME OF PARTS	RM
1	SB0772001	1	SB0808カマハコクミ	ROTARY HOOK ASSY W/BOX SB0808	
2	155479001	1	チヨウシバネ	TENSION SPRING	
3	151029001	1	チヨウシネジ	TENSION ADJUSTING SCREW	
4	151030001	1	チヨウシバネトメネジ	SET SCREW	
5	151035001	1	タルミトリバネトメネジ	SET SCREW	
6	155478001	1	シタイトタルミトリバネ	SPRING	
7	151027001	2	ウチカマオサエトメネジ	SET SCREW	
8	S09284001	1	シタイトホジイタ	LOW THREAD HOLDING PLATE	
9	SA8266001	1	シメネジSM1.59X1.6	SCREW SM1.59X1.6	
10	S09280001	1	キャツプクミ	CAP ASSY	

# T-8722D

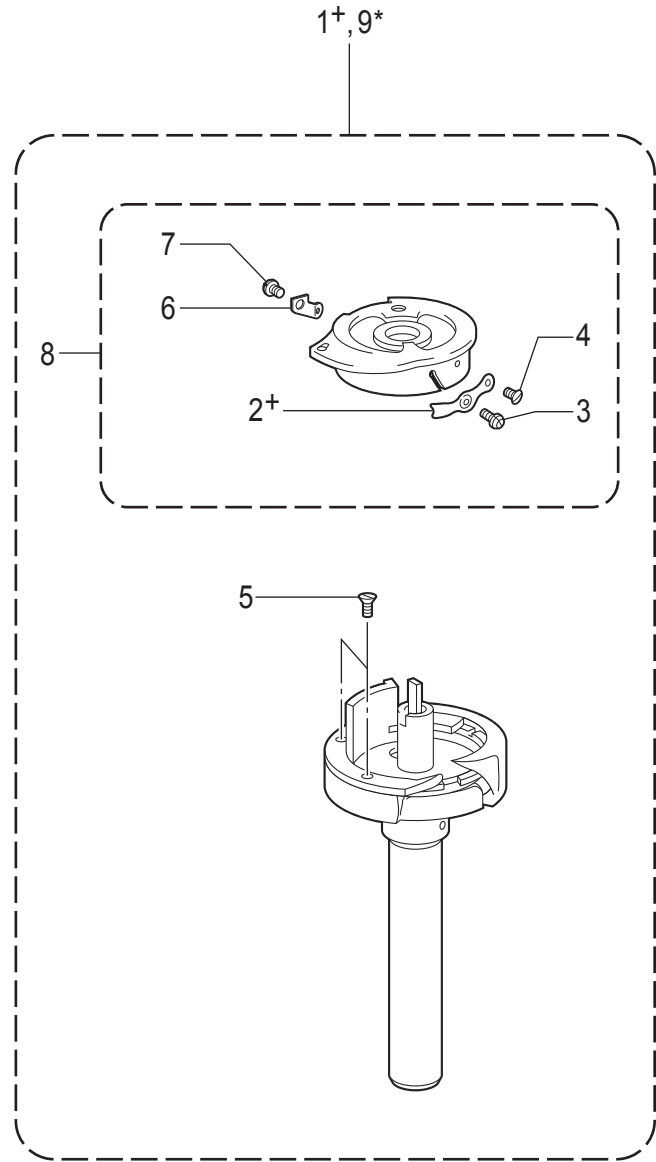
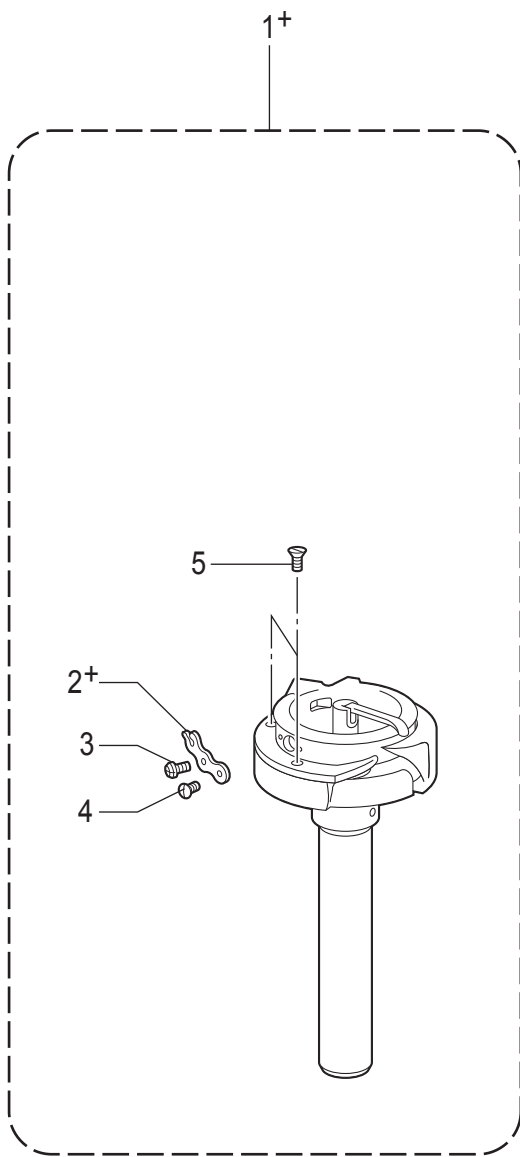

## J2. かま関係 / Rotary hook mechanism

REF.NO	CODE	Q'TY	品名	NAME OF PARTS	RM
1+	SC0191001	1	<キャップ無し> SC0035カマハコクミ	<Without cap> ROTARY HOOK ASSY W/BOX SC0035	
2+	151145001	1	チヨウシバネ <キャップ付>	TENSION SPRING <With cap>	
1+	SB0770001	1	SB0768カマハコクミ	ROTARY HOOK ASSY W/BOX SB0768	
2+	155479001	1	チヨウシバネ	TENSION SPRING	
6	S09284001	1	シタイトホジイタ	LOWER THREAD HOLDING PLATE	
7	SA8266001	1	シメネジSM1.59X1.6	SCREW SM1.59X1.6	
8	S09278001	1	キャップクミ	CAP ASSY	
3	151029001	1	チヨウシネジ	TENSION ADJUSTING SCREW	
4	151030001	1	チヨウシバネトメネジ	SET SCREW	
5	151027001	2	ウチカマオサエトメネジ	SET SCREW	
9*	SA1690011	1	<オプション部品: 剣先強化> S37003カマハコクミ	<Option parts: Rotary hook with reinforced hook point> ROTARY HOOK ASSY, W/BOX S37003	
<p>* かまの剣先を強化し、剣先の磨耗を防ぎます。ループのできにくい素材(伸縮性のあるものなど)の縫製で、かまの剣先を針に接触させて使うような場合に適しています。</p> <p>* The rotary hook point is reinforced to improve its durability. This type is suitable for sewing materials that are hard to make loops on the surface (like stretchy materials), and that requires making contact with the hook point and the needles.</p>					