

A. 机体部分 / Machine body

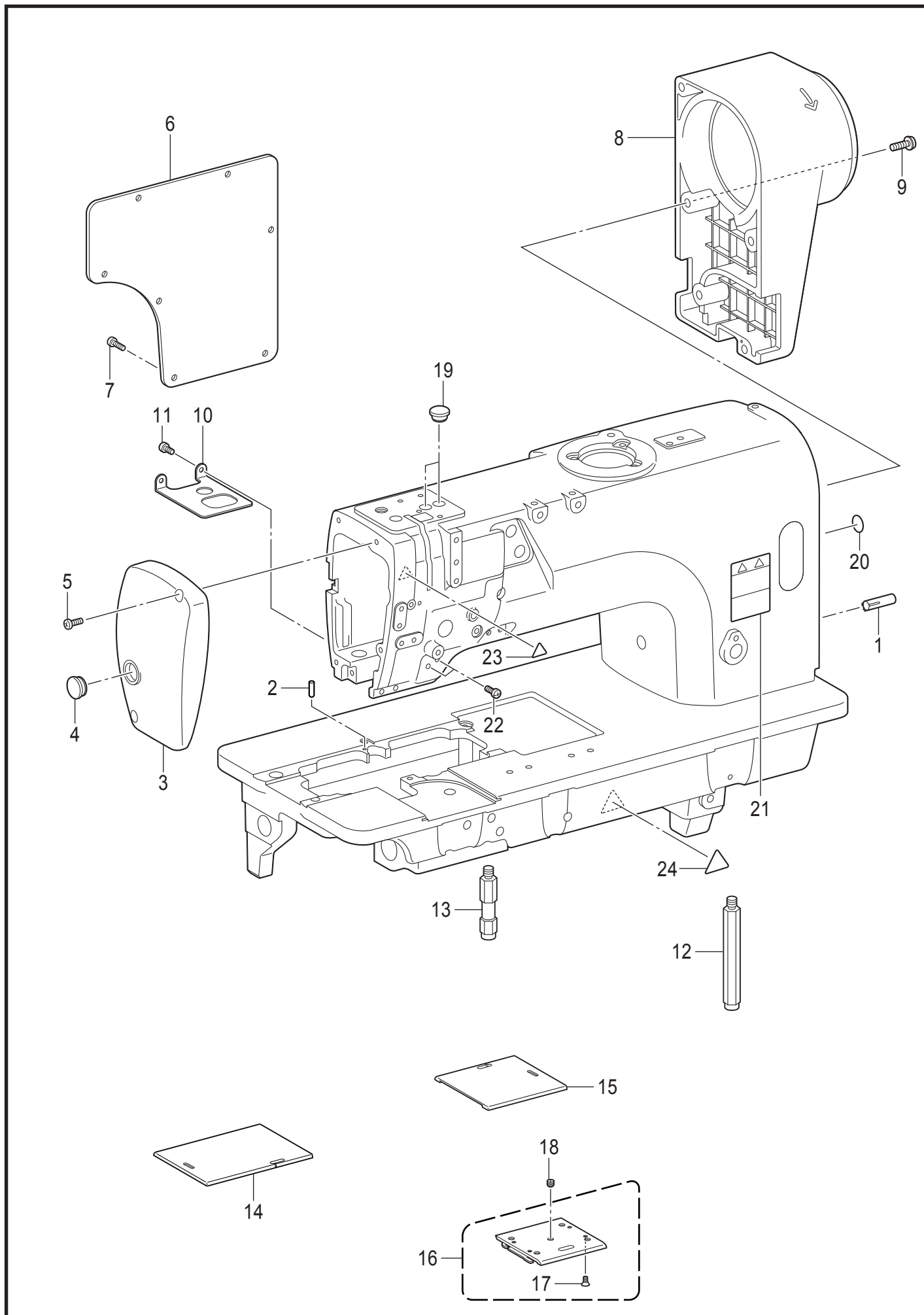

T-8452D-050

A. 机体部分 / Machine body

参照号	零部件序号	数量	零部件名称	NAME OF PARTS	RM
1	140063001	2	带槽销	DOWEL PIN	
2	SA3924001	1	定位销	POSITIONING PIN	
3	SB9875001	1	面板	FACE PLATE	
4	104449001	1	橡皮塞 15.5	RUBBER CAP, 15.5	
5	062501416	2	螺钉 M5X14	SCREW PAN M5X14	
6	SA2441201	1	侧板	REAR COVER	
7	062501216	7	螺钉 M5X12	SCREW PAN M5X12	
8	SB9863001	1	马达罩盖	MOTOR COVER	
9	SA9977101	5	螺钉(带垫圈)M5X18	SCREW PAN M5X18	
10	SA4370101	1	防尘板	DUST PROTECTOR	
11	062500616	2	螺钉 M5X6	SCREW PAN M5X6	
12	SA2444101	1	脚柱 L	BED LEG L	
13	SA2445101	1	脚柱 S	BED LEG S	
14	SA2448201	1	推板LA	SLIDE PLATE LA	
15	SA2450201	1	推板R	SLIDE PLATE R	
16	S36663101	1	推板F组件	SLIDE PLATE F ASSY	
17	S34438001	4	螺钉 SM3.18-40X4	SCREW FLAT SM3.18-40X4	
18	116010001	1	螺钉 SM5.16-40X4	SET SCREW, SM5.16-40X4	
19	SA2929001	2	橡皮塞 12.5	RUBBER CAP, 12.5	
20	S37060001	1	接地标记	LABEL GROUNDING	
21	SA9826001	1	操作注意标签	LABEL CAUTION	
22	062500816	2	螺钉 M5X8	SCREW PAN M5X8	
23	SA9957001	1	警告标记	INJURY MARK	
24	SA9957002	1	警告标记	INJURY MARK	