

## C2. 送料装置 / Feed mechanism

## BAS 341JX - 342JX

参照号	零部件序号	数量	零部件名称	NAME OF PARTS	RM
1	SA8578101	1	X手轮基座	X-PULLEY BRACKET	
2	SA8579001	1	手轮组件 A	PULLEY A ASSY	
3	SB5273001	2	轴承 6901	BEARING 6901	
4	SA8582001	1	手轮支点轴	PULLEY FULCRUM SHAFT	
5	012500536	2	螺钉 M5X5	SET SCREW SOCKET (FT) M5X5	
6	SA8583001	1	支点轴套	PULLEY FULCRUM SHAFT COLLAR	
7	SC4664001	1	皮带 1080	BELT 1080	
8	S47270001	2	螺栓(带垫圈) M6X30	BOLT SOCKET (S/P WASHER)M6X30	
9	SA8585001	1	X驱动轴	DRIVE SHAFT X	
10	048150142	2	轴用挡圈 C15	RETAINING RING EXTERNAL C15	
11	SA8586001	1	X齿轮	GEAR X	
12	012060636	4	螺钉 M6X6	SET SCREW SOCKET (FT) M6X6	
13	SB5273001	1	轴承 6901	BALL BEARING 6901	
14	SA8587001	1	手轮组件 B	PULLEY B ASSY	
15	012060636	4	螺钉 M6X6	SET SCREW SOCKET (FT) M6X6	
16	SC6356001	2	轴承 6202	BALL BEARING RADIAL 6202	
17	SA8592101	2	Y手轮基座	Y-PULLEY BRACKET	
18	SA8579001	2	手轮组件 A	PULLEY A ASSY	
19	SC6356001	4	轴承 6202	BALL BEARING RADIAL 6202	
20	SA8582001	2	手轮支点轴	PULLEY FULCRUM SHAFT	
21	012500536	4	螺钉 M5X5	SET SCREW SOCKET (FT) M5X5	
22	SA8583001	2	支点轴套	PULLEY FULCRUM SHAFT COLLAR	
23	SC4665001	2	皮带 775	BELT 775	
24	SC5520001	1	Y驱动轴	DRIVE SHAFT Y	
25	SA8596001	1	Y齿轮	GEAR Y	
26	012060636	4	螺钉 M6X6	SET SCREW SOCKET (FT) M6X6	
27	SA8587001	2	手轮组件 B	PULLEY B ASSY	
28	012060636	8	螺钉 M6X6	SET SCREW SOCKET (FT) M6X6	
29	SC6355001	2	轴承 6002	BEARING 6002	
30	SC6356001	2	轴承 6202	BALL BEARING RADIAL 6202	
31	SA8597001	2	螺栓 M5X12	BOLT SOCKET M5X12	
32	S47270001	4	螺栓(带垫圈) M6X30	BOLT SOCKET (S/P WASHER)M6X30	
33	SA8604001	1	X马达基座	MOTOR BRACKET X	
34	SA8599001	1	轴承 6201	BEARING 6201	
35	SC1676101	1	脉冲马达组件 X	PULSE MOTOR ASSY X	
36	018501636	4	螺栓 M5X16	BOLT SOCKET M5X16	
37	SA8607101	1	X马达齿轮	MOTOR GEAR X	
38	012060636	2	螺钉 M6X6	SET SCREW SOCKET (FT) M6X6	
39	S47270001	4	螺栓(带垫圈) M6X30	BOLT SOCKET (S/P WASHER)M6X30	
40	SC5522001	1	Y马达基座	MOTOR BRACKET Y	
41	SA8599001	1	轴承 6201	BEARING 6201	
42	SC1678001	1	脉冲马达组件 Y	PULSE MOTOR ASSY Y	
43	018501636	4	螺栓 M5X16	BOLT SOCKET M5X16	
44	SA8601001	1	Y马达齿轮	MOTOR GEAR Y	
45	012060636	2	螺钉 M6X6	SET SCREW SOCKET (FT) M6X6	
46	S47269001	4	螺栓(带垫圈) M6X20	BOLT SOCKET (S/P WASHER)M6X20	
47	SA8694001	1	风扇安装板	FAN BRACKET	
48	018400836	2	螺栓 M4X8	BOLT SOCKET M4X8	
49	104449001	1	橡皮塞 15.5	RUBBER CAP, 15.5	

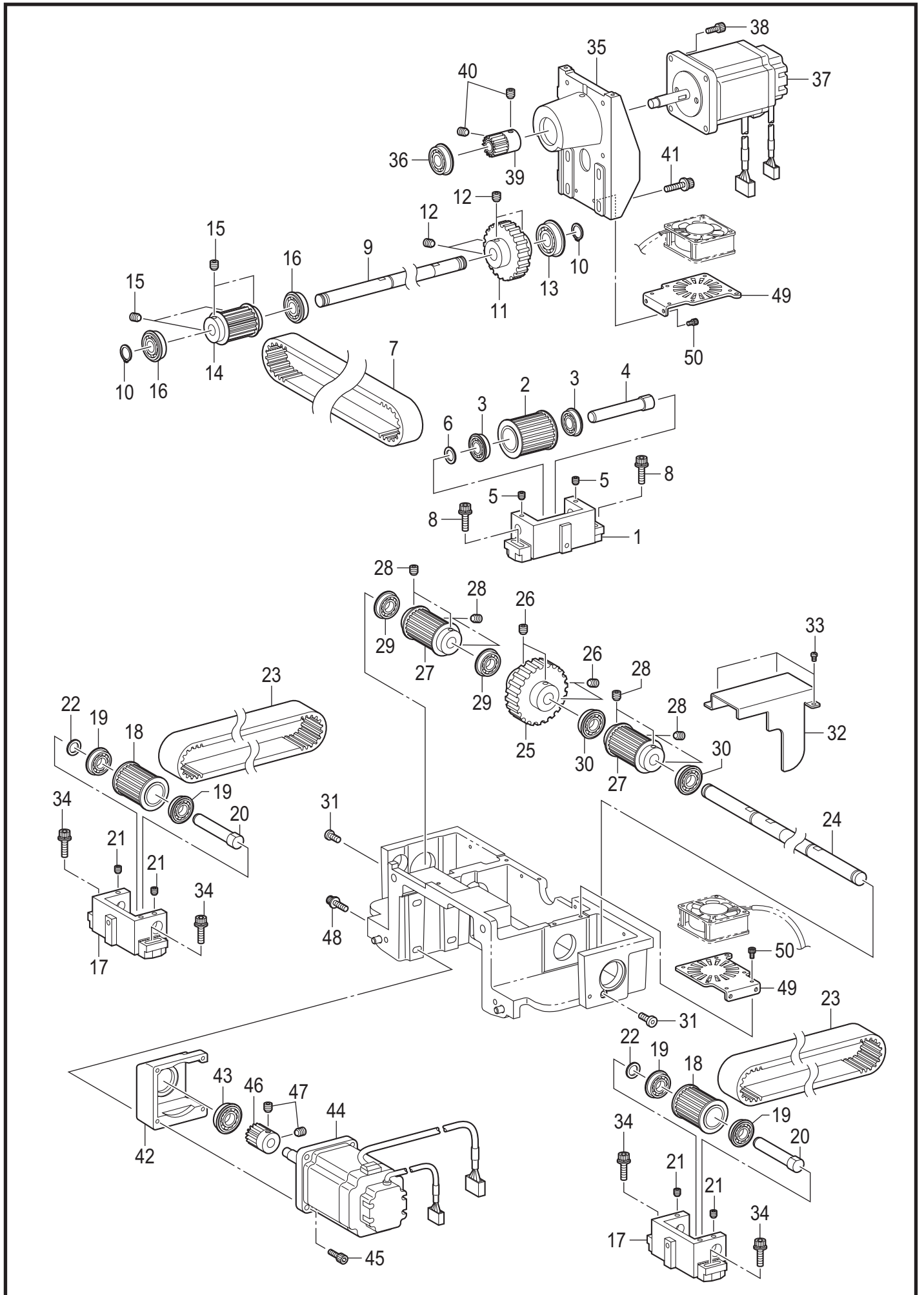

## C2. 送り関係 / Feed mechanism

REF.NO	CODE	Q'TY	品名	NAME OF PARTS	RM
1	SA8578101	1	Xプーリーダイ	X-PULLEY BRACKET	
2	SA8579001	1	プーリー-Aクミ	PULLEY A ASSY	
3	SA1283001	2	タマジクウケ6901ZZNR	BALL BEARING, 6901ZZNR	
4	SA8582001	1	プーリー-シテンジク	PULLEY FULCRUM SHAFT	
5	012500536	2	アナヒラ5X5	SET SCREW SOCKET (FT) M5X5	
6	SA8583001	1	プーリー-シテンジクカラ	PULLEY FULCRUM SHAFT COLLAR	
7	SA8584001	1	X-GTベルト	X-GT BELT	
8	S47270001	2	アナボルトザクミ6X30	BOLT SOCKET (S/P WASHER)M6X30	
9	SA8585001	1	Xクドウジク	DRIVE SHAFT X	
10	048150142	2	トメワジクヨウC15	RETAINING RING EXTERNAL C15	
11	SA8586001	1	Xゲンソクギヤ	GEAR X	
12	012060636	4	アナヒラ6X6	SET SCREW SOCKET (FT) M6X6	
13	SA6674001	1	タマジクウケ6002ZZNR	BALL BEARING 6002ZZNR	
14	SA8587001	1	プーリー-Bクミ	PULLEY B ASSY	
15	012060636	4	アナヒラ6X6	SET SCREW SOCKET (FT) M6X6	
16	076202856	2	Rタマジクウケ6202ZZNR	BALL BEARING RADIAL 6202ZZNR	
17	SA8592101	2	Yプーリーダイ	Y-PULLEY BRACKET	
18	SA8579001	2	プーリー-Aクミ	PULLEY A ASSY	
19	SA1283001	4	タマジクウケ6901ZZNR	BALL BEARING, 6901ZZNR	
20	SA8582001	2	プーリー-シテンジク	PULLEY FULCRUM SHAFT	
21	012500536	4	アナヒラ5X5	SET SCREW SOCKET (FT) M5X5	
22	SA8583001	2	プーリー-シテンジクカラ	PULLEY FULCRUM SHAFT COLLAR	
23	SA8593001	2	Y-GTベルト	Y-GT BELT	
24	SA8595001	1	Yクドウジク	DRIVE SHAFT Y	
25	SA8596001	1	Yゲンソクギヤ	GEAR Y	
26	012060636	4	アナヒラ6X6	SET SCREW SOCKET (FT) M6X6	
27	SA8587001	2	プーリー-Bクミ	PULLEY B ASSY	
28	012060636	8	アナヒラ6X6	SET SCREW SOCKET (FT) M6X6	
29	SA6674001	2	タマジクウケ6002ZZNR	BALL BEARING 6002ZZNR	
30	076202856	2	Rタマジクウケ6202ZZNR	BALL BEARING RADIAL 6202ZZNR	
31	SA8597001	2	タイトウアナボルト5X12	BOLT SOCKET M5X12	
32	SA8602001	1	Yクドウギヤカバー	COVER GEAR Y	
33	062400816	3	ナベコ4X8	SCREW PAN M4X8	
34	S47270001	4	アナボルトザクミ6X30	BOLT SOCKET (S/P WASHER)M6X30	
35	SA8604001	1	Xモーターブラケット	MOTOR BRACKET X	
36	SA8599001	1	タマジクウケ6201ZZNR	BALL BEARING 6201ZZNR	
37	SC1676101	1	パルスモータXクミ	PULSE MOTOR ASSY X	
38	018501636	4	アナボルト5X16	BOLT SOCKET M5X16	
39	SA8607101	1	Xモーターギヤ	MOTOR GEAR X	
40	012060636	2	アナヒラ6X6	SET SCREW SOCKET (FT) M6X6	
41	S47270001	4	アナボルトザクミ6X30	BOLT SOCKET (S/P WASHER)M6X30	
42	SA8598001	1	Yモーターブラケット	MOTOR BRACKET Y	
43	SA8599001	1	タマジクウケ6201ZZNR	BALL BEARING 6201ZZNR	
44	SB6014001	1	パルスモータYクミ	PULSE MOTOR ASSY Y	
45	018501636	4	アナボルト5X16	BOLT SOCKET M5X16	
46	SA8601001	1	Yモーターギヤ	MOTOR GEAR Y	
47	012060636	2	アナヒラ6X6	SET SCREW SOCKET (FT) M6X6	
48	S47269001	4	アナボルトザクミ6X20	BOLT SOCKET (S/P WASHER)M6X20	
49	SA8694001	2	ファンリツケイタ	FAN BRACKET	
50	018400836	4	アナボルト4X8	BOLT SOCKET M4X8	